



ONE STOP FOR
YOUR COMPLETE TOOLING

Solution.....



CNMG External Tool Holder

95° MCLNR/L

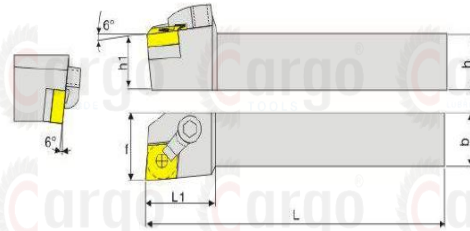
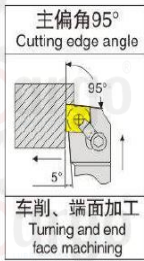

DESIGNATION	Dimension(mm)						Accessories				
	h	b	L	L1	hl	f	SHIM	Shim pin	clamp	screw clamp	Wrench
MCLNR/L 16X16 HI2	16	16	100	32	16	20	MC1204	CTM 617	HL1814	ML0625	L2.5,L3.0
MCLNR/L 20X20 HI2	20	20	125	22	20	25					
MCLNR/L 25X25 HI2	25	25	150	32	25	32					
MCLNR/L 25X25 M16	25	25	150	32	25	32					

75° MCKNR/L

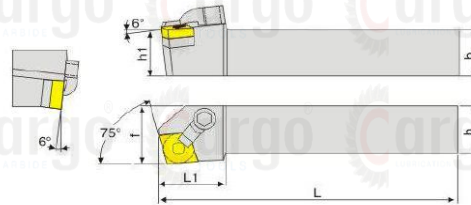

DESIGNATION	Dimension(mm)						Accessories				
	h	b	L	L1	hl	f	SHIM	Shim pin	clamp	screw clamp	Wrench
MCKNR/L 20X20 HI2	20	20	125	32	20	17	MC1204	CTM 617	HL1814	ML0625	L2.5,L3.0
MCKNR/L 25X25 HI2	25	25	150	32	25	22					

75° MCBNR/L

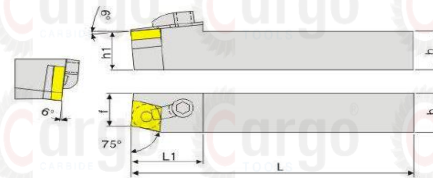

DESIGNATION	Dimension(mm)						Accessories				
	h	b	L	L1	hl	f	SHIM	Shim pin	clamp	screw clamp	Wrench
MCBNR/L 20X20 HI2	20	20	125	32	20	17	MC1204	CTM 617	HL1814	ML0625	L2.5,L3.0
MCBNR/L 25X25 HI2	25	25	150	32	25	22					

SNMG External Tool Holder

75° MSBNR/L

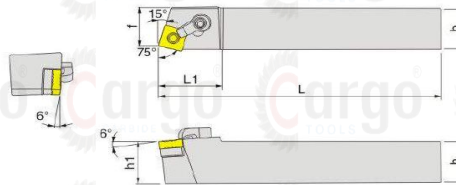
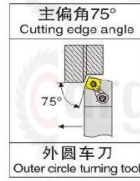

DESIGNATION	Dimension(mm)						Accessories				
	h	b	L	L1	h1	f	SHIM	Shim pin	clamp	screw clamp	Wrench
MSBNR/L 16X16 H12	16	16	100	32	16	20	MSI2D4	CTM617	HL814	MLO625	L2.5.L3.0
MSBNR/L 20X20 H12	20	20	125	32	20	25					
MSBNR/L 25X25 H12	25	25	150	32	25	32					

45° MSSNR/L

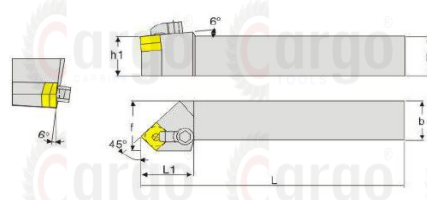

DESIGNATION	Dimension(mm)						Accessories				
	h	b	L	L1	h1	f	SHIM	Shim pin	clamp	screw clamp	Wrench
MSSNR/L 20X20 H12	20	20	125	34	25	20	MSI2D4	CTM617	HL814	MLO625	L2.5.L3.0
MSSNR/L 25X25 H12	25	25	150	34	32	25					

45° MSDNN

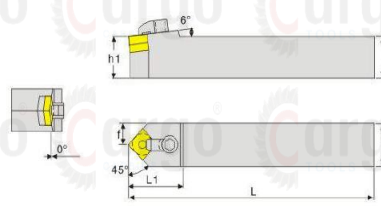
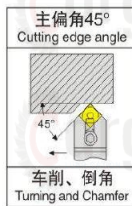

DESIGNATION	Dimension(mm)						Accessories				
	h	b	L	L1	h1	f	SHIM	Shim pin	clamp	screw clamp	Wrench
MSDNN 16X16 H12	16	16	100	34	16	8	MSI2D4	CTM617	HL814	MLO625	L2.5.L3.0
MSDNN 20X20 H12	20	20	125	34	20	10					
MSDNN 25X25 H12	25	25	150	34	25	12.5					

75° MSKNR/L

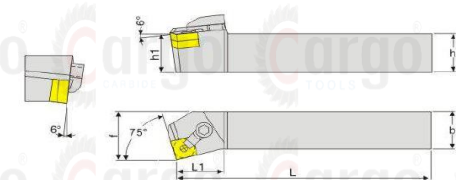

DESIGNATION	Dimension(mm)						Accessories				
	h	b	L	L1	h1	f	SHIM	Shim pin	clamp	screw clamp	Wrench
MSKNR/L 20X20 H12	20	20	125	32	20	25	MSI2D4	CTM617	HL814	MLO625	L2.5.L3.0
MSKNR/L 25X25 H12	25	25	150	32	25	32					

WNMG External Tool Holder

■ 95° MWLNR/L

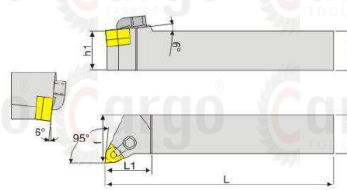

DESIGNATION	Dimension(mm)						Accessories				
	h	b	L	L1	h1	f	SHIM	Shim pin	clamp	screw clamp	Wrench
MWLNR/L 16X16 H06	16	16	100	23	16	20	MW0603	CTM513	HL1814	ML0625	L2.0.L3.0
MWLNR/L 20X20 H06	20	20	125	23	20	25					
MWLNR/L 25X25 H06	25	25	150	23	25	32					
MWLNR/L 16X16 H08	16	16	100	25	16	20	MW0803	CTM617	HL1814	ML0625	L2.5.L3.0
MWLNR/L 20X20 H08	20	20	125	25	20	25					
MWLNR/L 25X25 H08	25	25	150	25	25	32					

WNMG Internal Tool Holder

■ MWLNR/L

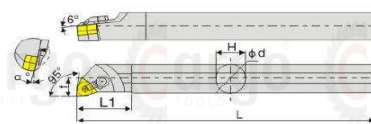
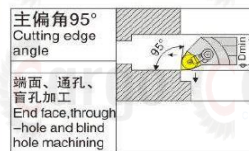

DESIGNATION	Dimension(mm)						Accessories				
	DMIN	Dd	f	L	H	α°	SHIM	Shim pin	clamp	screw clamp	Wrench
S16 MWLNR/L M06	22	16	11	160	15	18	MW0603	CTM513	HL1814	ML0625	L2.0.L3.0
S20 MWLNR/L M06	25	20	13	180	19	15					
S25 MWLNR/L M06	32	25	17	200	24	12					
S32 MWLNR/L M06	40	32	22	250	30	17	MW0803	CTM617	HL1814	ML0625	L2.5.L3.0
S20 MWLNR/L M08	23	20	13	180	19	15					
S25 MWLNR/L M08	30	25	17	200	24	12					
S32 MWLNR/L M08	38	32	22	250	30	17					

DNMG External Tool Holder

93° MDJNR/L

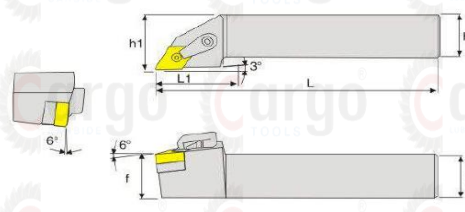
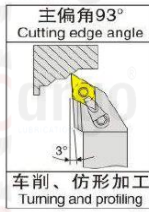

DESIGNATION	Dimension(mm)						Accessories				
	h	b	L	L1	h1	f	SHIM	Shim pin	clamp	screw clamp	Wrench
MDJNR/L 16X16 H11	16	16	100	23	16	20	MD1103	CTM513	HL1814	ML0625	L2.0.L3.0
MDJNR/L 20X20 H11	20	20	125	23	20	25					
MDJNR/L 25X25 H11	25	25	150	23	25	32	MD1506	CTM619	HL2114	ML0625	L2.0.L3.0
MDLNR/L 20X20 H15	20	20	125	25	20	25					
MDLNR/L 25X25 H15	25	25	150	25	25	32					

62.5° MDPNN

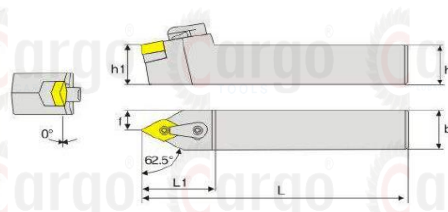
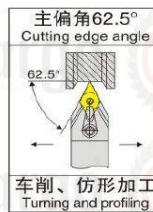

DESIGNATION	Dimension(mm)						Accessories				
	h	b	L	L1	h1	f	SHIM	Shim pin	clamp	screw clamp	Wrench
MDPNN 16X16 H11	16	16	100	23	16	20	MD1103	CTM513	HL1814	ML0625	L2.0.L3.0
MDPNN 20X20 H11	20	20	125	23	20	25					
MDPNN 25X25 H11	25	25	150	23	25	32	MD1506	CTM619	HL2114	ML0625	L2.0.L3.0
MDPNN 20X20 H15	20	20	125	25	20	25					
MDPNN 25X25 H15	25	25	150	25	25	32					

107°30' MDQNR/L

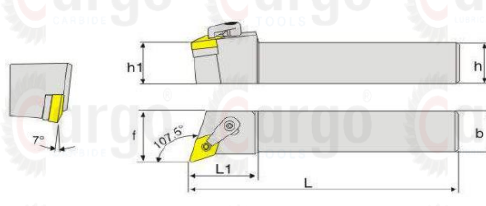

DESIGNATION	Dimension(mm)						Accessories				
	h	b	L	L1	h1	f	SHIM	Shim pin	clamp	screw clamp	Wrench
MDQNR/L 20X20 H15	20	20	125	36	20	25	MD1506	CTM619	HL2114	ML0625	L2.0.L3.0
MDQNR/L 25X25 H15	25	25	150	36	25	32					

TNMG External Tool Holder

93° MTJNR/L

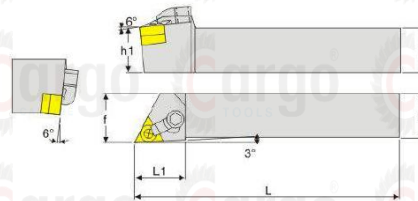
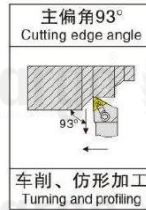

DESIGNATION	Dimension(mm)						Accessories				
	h	b	L	L1	h1	f	SHIM	Shim pin	clamp	screw clamp	Wrench
MTJNR/L 16X16 H16	16	16	100	28	16	20	MT1603	CTM513	HL1814	ML0625	L2.0.L3.0
MTJNR/L 20X20 H16	20	20	125	28	20	25					
MTJNR/L 25X25 H16	25	25	150	28	25	32	MT2204	CTM617	HL1917	ML0830	L2.5.L4.0
MTJNR/L 25X25 M22	16	16	100	32	16	20					

15° MTQNR/L

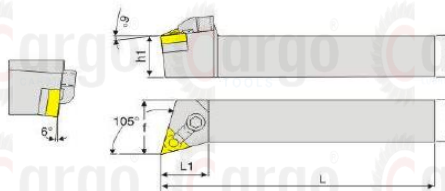
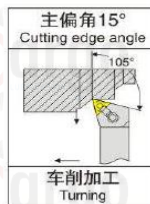

DESIGNATION	Dimension(mm)						Accessories				
	h	b	L	L1	h1	f	SHIM	Shim pin	clamp	screw clamp	Wrench
MTQNR/L 16X16 H16	16	16	100	28	16	20	MT1603	CTM513	HL1814	ML0625	L2.0.L3.0
MTQNR/L 20X20 H16	20	20	125	28	20	25					
MTQNR/L 25X25 H16	25	25	150	28	25	32	MT2204	CTM617	HL1917	ML0830	L2.5.L4.0
MTQNR/L 25X25 M22	16	16	100	32	16	20					

60° MTENN

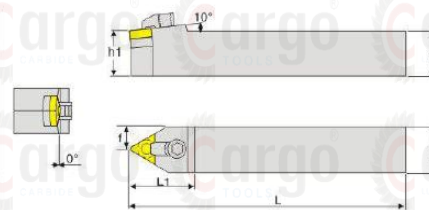
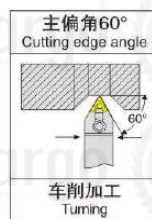

DESIGNATION	Dimension(mm)						Accessories				
	h	b	L	L1	h1	f	SHIM	Shim pin	clamp	screw clamp	Wrench
MTENN 20X20 H16	20	20	125	35	20	10	MT1603	CTM513	HL1814	ML0625	L2.0.L3.0
MTENN 25X25 H16	25	25	150	35	25	12.5					
MTENN 25X25 M22	25	25	150	38	25	12.5	MT2204	CTM617	HL1917	ML0830	L2.5.L4.0

VNMG External Tool Holder

■ 93° MVJNR/L

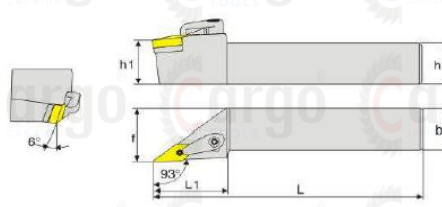

DESIGNATION	Dimension(mm)						Accessories				
	h	b	L	L1	h1	f	SHIM	Shim pin	clamp	screw clamp	Wrench
MVJNR/L 20X20 H16	20	20	125	36	20	25	MV1603	CTM513	HL2414	MLO625	L2.0.L3.0
MVJNR/L 25X25 H16	25	25	150	42	25	32					

■ 72.5° MVVNN

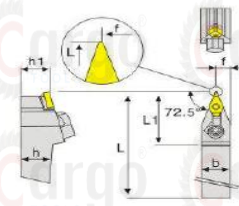
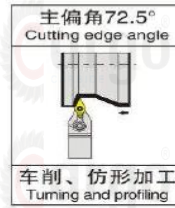

DESIGNATION	Dimension(mm)						Accessories				
	h	b	L	L1	h1	f	SHIM	Shim pin	clamp	screw clamp	Wrench
MVVNN 20X20 H16	20	20	125	48	20	10	MV1603	CTM513	HL2414	MLO625	L2.0.L3.0
MVVNN 25X25 H16	25	25	150	48	25	12.5					

■ 95° MVUNR/L

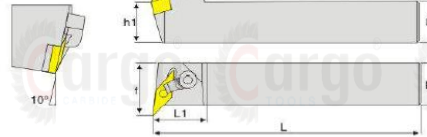

DESIGNATION	Dimension(mm)						Accessories				
	h	b	L	L1	h1	f	SHIM	Shim pin	clamp	screw clamp	Wrench
MVUNR/L 20X20 H16	20	20	125	21	20	25	MV1603	CTM513	HL2414	MLO625	L2.0.L3.0
MVUNR/L 25X25 H16	25	25	150	21	25	32					

■ 117.5° MVQNR/L

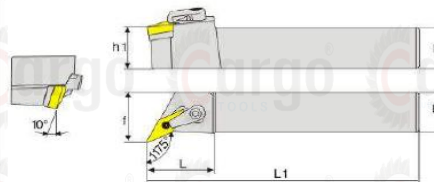
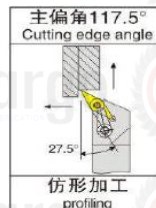

DESIGNATION	Dimension(mm)						Accessories				
	h	b	L	L1	h1	f	SHIM	Shim pin	clamp	screw clamp	Wrench
MVQNR/L 20X20 H16	20	20	125	21	20	25	MV1603	CTM513	HL2414	MLO625	L2.0.L3.0
MVQNR/L 25X25 H16	25	25	150	21	25	32					

VBMT External Tool Holder

■ 93° SVJBR/L

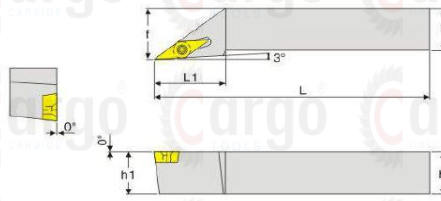
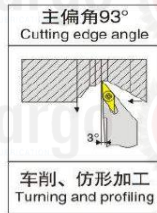

DESIGNATION	Dimension(mm)						Accessories		INSERT SIZE
	h	b	L	L1	h1	f	SCREW	WRENCH	
SVJBR/L 20X20 H11	20	20	125	32	20	25	M2.5X8	T-15	VBMT 11
SVJBR/L 25X25 H11	25	25	150	32	25	32			
SVJBR/L 20X20 H16	20	20	125	32	20	25	M3.5X9	T-15	VBMT 16
SVJBR/L 25X25 H16	25	25	150	32	25	32			

■ 72.5° SVVBN

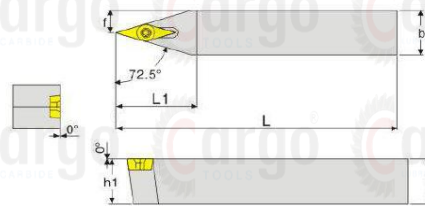
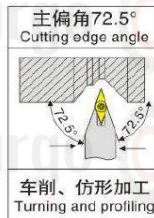

DESIGNATION	Dimension(mm)						Accessories		INSERT SIZE
	h	b	L	L1	h1	f	SCREW	WRENCH	
SVVBN 20X20 H11	20	20	125	24	20	10	M2.5X8	T-15	VBMT 11
SVVBN 25X25 H11	25	25	150	24	25	12.5			
SVVBN 20X20 H16	20	20	125	24	20	10	M3.5X9	T-15	VBMT 16
SVVBN 25X25 H16	25	25	150	24	25	12.5			

■ 117.5° SVQBR/L

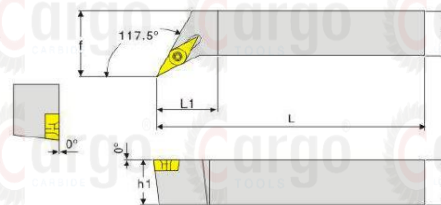
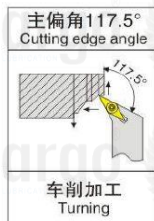

DESIGNATION	Dimension(mm)						Accessories		INSERT SIZE
	h	b	L	L1	h1	f	SCREW	WRENCH	
SVQBR/L 20X20 H11	20	20	125	32	20	25	M2.5X8	T-15	VBMT 11
SVQBR/L 25X25 H11	25	25	150	32	25	32			
SVQBR/L 20X20 H16	20	20	125	32	20	25	M3.5X9	T-15	VBMT 16
SVQBR/L 25X25 H16	25	25	150	32	25	32			

CCMT External Tool Holder

95° SCLCR/L

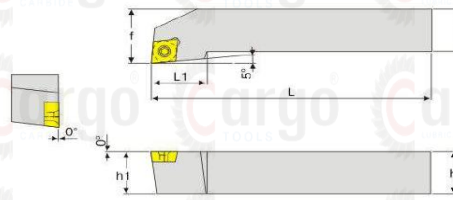

DESIGNATION	Dimension(mm)						Accessories		INSERT SIZE
	h	b	L	L1	h1	f	SCREW	WRENCH	
SCLCR/L 10X10 09	10	10	70	10	12	12	M4X8	T15	CCMT 09
SCLCR/L 12X12 09	12	12	80	12	16	16			
SCLCR/L 16X16 09	16	16	100	16	20	16			
SCLCR/L 20X20 09	20	20	125	20	25	16			
SCLCR/L 25X25 09	25	25	150	25	32	16	M5X12	T20	CCMT 12
SCLCR/L 20X20 12	20	20	125	20	25	20			
SCLCR/L 25X25 12	25	25	150	25	32	20			
SCLCR/L 32X32 12	32	32	170	32	40	20			

75° SCKCR/L

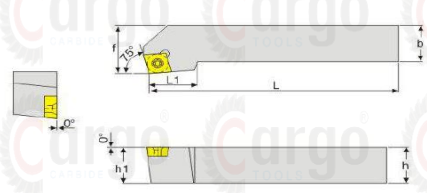

DESIGNATION	Dimension(mm)						Accessories		INSERT SIZE
	h	b	L	L1	h1	f	SCREW	WRENCH	
SCKCR/L 20X20 09	20	20	125	20	25	16	M4X8	T15	CCMT 09
SCKCR/L 25X25 09	25	25	150	25	32	16			
SCKCR/L 20X20 12	20	20	125	20	25	20	M5X12	T20	CCMT 12
SCKCR/L 25X25 12	25	25	150	25	32	20			

50° SCMCN

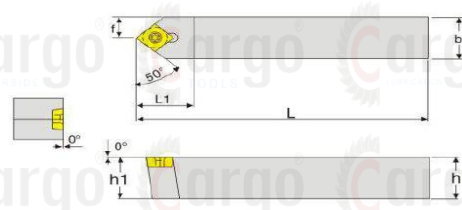
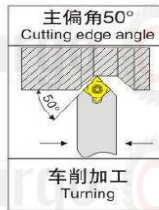

DESIGNATION	Dimension(mm)						Accessories		INSERT SIZE
	h	b	L	L1	h1	f	SCREW	WRENCH	
SCMCN 20X20 M09	20	20	125	18	20	10	M4X8	T15	CCMT 09
SCMCN 25X25 M09	25	25	150	18	25	12.5			
SCMCN 20X20 M12	20	20	125	18	20	10	M5X12	T20	CCMT 12
SCMCN 25X25 M12	25	25	150	18	25	12.5			

DCMT External Tool Holder

93° SDJCR/L

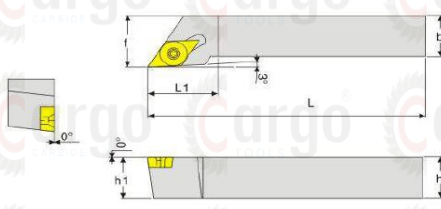

DESIGNATION	Dimension(mm)						Accessories		INSERT SIZE
	h	b	L	L1	h1	f	SCREW	WRENCH	
SDJCR/L 10X10 07	10	10	80	12	10	14	M2.5X6	T8	DCMT 07
SDJCR/L 12X12 07	12	12	80	16	12	14			
SDJCR/L 16X16 07	16	16	100	20	16	18			
SDJCR/L 20X20 II	20	20	125	20	20	24	M4X8	T15	DCMT II
SDJCR/L 25X25 II	25	25	150	23	25	29			

62.5° SDNCN

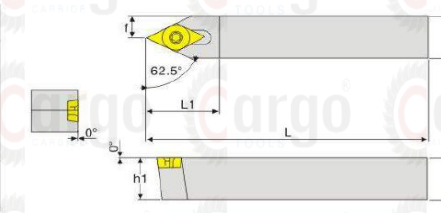

DESIGNATION	Dimension(mm)						Accessories		INSERT SIZE
	h	b	L	L1	h1	f	SCREW	WRENCH	
SDNCN 10X10 07	10	10	80	14	10	5	M2.5X6	T8	DCMT 07
SDNCN 12X12 07	12	12	80	14	12	6			
SDNCN 16X16 II	16	16	100	21	12	6			
SDNCN 20X20 II	20	20	125	21	20	10	M4X8	T15	DCMT II
SDNCN 25X25 II	25	25	150	21	25	12.5			

107.5° SDQCR/L

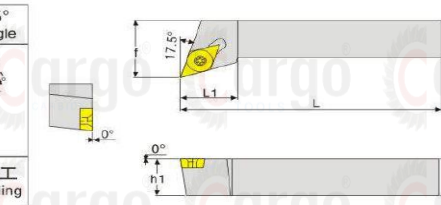

DESIGNATION	Dimension(mm)						Accessories		INSERT SIZE
	h	b	L	L1	h1	f	SCREW	WRENCH	
SDJCR/L 10X10 07	10	10	100	12.5	10	12	M2.5X6	T8	DCMT 07
SDJCR/L 12X12 07	12	12	100	13	12	16			
SDJCR/L 16X16 II	16	16	100	14	16	20			
SDJCR/L 20X20 II	20	20	125	16	20	25	M4X8	T15	DCMT II
SDJCR/L 25X25 II	25	25	150	22	25	32			

TCMT External Tool Holder

91° STFCR/L

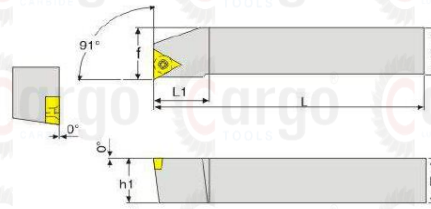

DESIGNATION	Dimension(mm)						Accessories		INSERT SIZE
	h	b	L	L1	h1	f	SCREW	WRENCH	
STFCR/L 12X12 M09	12	12	80	12	16	14	M2.2X6	T6	TCMT 09
STFCR/L 12X12 M11	12	12	80	12	16	14	M2.5X6	T8	TCMT 11
STFCR/L 16X16 M11	16	16	100	16	20	14		T8	
STFCR/L 20X20 I6	20	20	125	20	25	22	M4X9	T15	TCMT 16
STFCR/L 25X25 I6	25	25	150	25	32	22		T15	

ROUND INSERT External Tool Holder

SRDCN

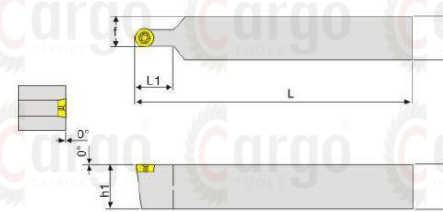

DESIGNATION	Dimension(mm)						Accessories		INSERT SIZE
	h	b	L	L1	h1	f	SCREW	WRENCH	
SRDCN 20X20 M10	20	20	125	20	15	20.3	M4X10	T15	RPMT 10
SRDCN 25X25 M10	25	25	150	25	17.5	20.3			

SRACR/L

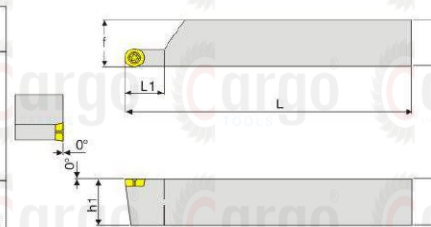
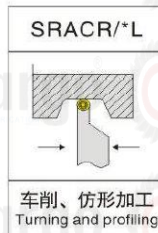

DESIGNATION	Dimension(mm)						Accessories		INSERT SIZE
	h	b	L	L1	h1	f	SCREW	WRENCH	
SRDCN 20X20 M10	20	20	125	20	20	20.3	M4X10	T15	RPMT 10
SRDCN 25X25 M10	25	25	150	20	25	25.4			

CNMG Internal Tool Holder

■ MCLNR/L

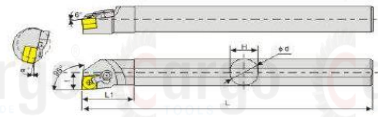
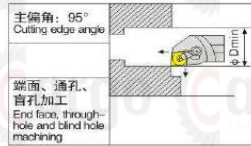

DESIGNATION	Dimension(mm)						Accessories				
	DMIN	φd	L1	L	H	α°	SHIM	Shim pin	clamp	screw clamp	Wrench
S20 MCLNR/L M12	23	20	45	180	19	15	MC1204	CTM613	HL 1810	MLO620	L2.5,L3.0
S25 MCLNR/L M12	30	25	45	200	24	12					
S32 MCLNR/L M12	38	32	50	250	30	17					
S40MCLNR/L M12	47	40	55	300	38	15					

■ MCKNR/L

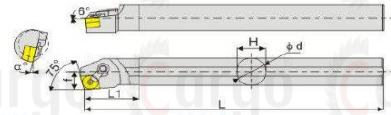
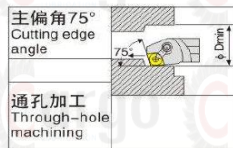

DESIGNATION	Dimension(mm)						Accessories				
	DMIN	φd	L1	L	H	α°	SHIM	Shim pin	clamp	screw clamp	Wrench
S20 MCKNR/L M12	23	20	45	180	19	15	MC1204	CTM613	HL 1810	MLO620	L2.5,L3.0
S25 MCKNR/L M12	30	25	45	200	24	12					
S32 MCKNR/L M12	38	32	50	250	30	17					
S40 MCKNR/L M12	47	40	55	300	38	15					

SNMG Internal Tool Holder

■ MSKNR/L

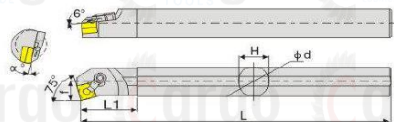

DESIGNATION	Dimension(mm)						Accessories				
	DMIN	φd	L1	L	H	α°	SHIM	Shim pin	clamp	screw clamp	Wrench
S20 MSKNR/L M12	23	20	40	180	19	15	MS1204	CTM613	HL 1810	MLO620	L2.5,L3.0
S25 MSKNR/L M12	30	25	45	200	24	12					
S32 MSKNR/L M12	38	32	50	250	30	17					
S40 MSKNR/L M12	47	40	55	300	38	15					

DNMG Internal Tool Holder

■ MDUNR/L

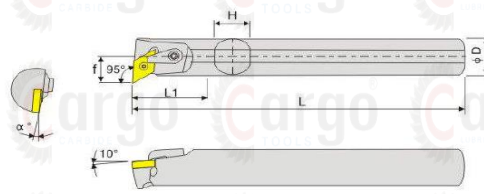

DESIGNATION	Dimension(mm)						Accessories				
	DMIN	φd	L1	L	H	α°	SHIM	Shim pin	clamp	screw clamp	Wrench
S25 MDUNR/L M15	32	25	45	200	24	12	M1506	CTM619	HLZ114	ML0625	L2.5.L3.0
S32 MDUNR/L M15	40	32	50	250	30	17					
S40 MDUNR/L M15	50	40	60	300	38	15					

■ MDZNR/L

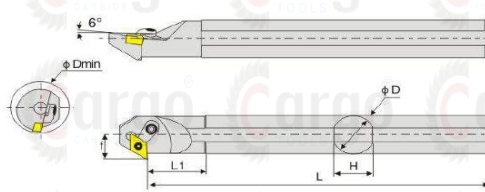
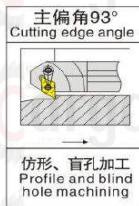

DESIGNATION	Dimension(mm)						Accessories				
	DMIN	φd	L1	L	H	α°	SHIM	Shim pin	clamp	screw clamp	Wrench
S25 MDZNR/L M15	32	25	45	200	24	12	M1506	CTM619	HLZ114	ML0625	L2.5.L3.0
S32 MDZNR/L M15	40	32	50	250	30	17					
S40 MDZNR/L M15	50	40	60	300	38	15					

■ MDQNR/L

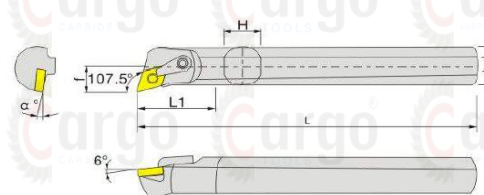

DESIGNATION	Dimension(mm)						Accessories				
	DMIN	φd	L1	L	H	α°	SHIM	Shim pin	clamp	screw clamp	Wrench
S25 MDQNR/L M15	32	25	45	200	24	12	M1506	CTM619	HLZ114	ML0625	L2.5.L3.0
S32 MDQNR/L M15	40	32	50	250	30	17					
S40 MDQNR/L M15	50	40	60	300	38	15					

VNMG Internal Tool Holder

■ MVUNR/L

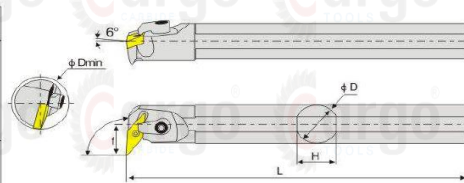

DESIGNATION	Dimension(mm)						Accessories				
	DMIN	∅d	f	L	H	α°	SHIM	Shim pin	clamp	screw clamp	Wrench
S25 MVUNR/L M16	36	25	20	200	24	12	MV1603	CTM513	HL2414	ML0625	L2.5.L3.0
S32 MVUNR/L M16	42	32	22	250	30	17					
S40 MVUNR/L M16	50	40	27	300	38	15					

■ MVQNR/L

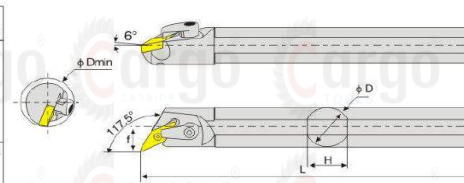

DESIGNATION	Dimension(mm)						Accessories				
	DMIN	∅d	f	L	H	α°	SHIM	Shim pin	clamp	screw clamp	Wrench
S25 MVQNR/L M16	36	25	17	200	24	12	MV1603	CTM513	HL2414	ML0625	L2.5.L3.0
S32 MVQNR/L M16	42	32	23	250	30	17					
S40 MVQNR/L M16	50	40	27	300	38	15					

■ MVWNR/L

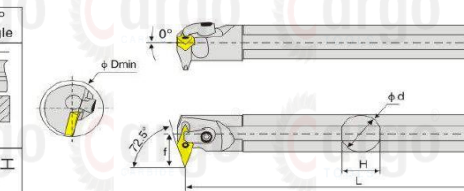
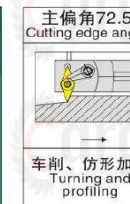

DESIGNATION	Dimension(mm)						Accessories				
	DMIN	∅d	f	L	H	α°	SHIM	Shim pin	clamp	screw clamp	Wrench
S25 MVWNR/L M16	40	25	26	200	24	12	MV1603	CTM513	HL2414	ML0625	L2.5.L3.0
S32 MVWNR/L M16	48	32	30	250	30	17					
S40 MVWNR/L M16	50	40	38	300	38	15					

■ MVXNR/L

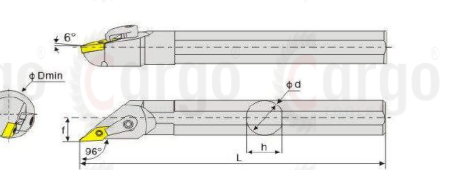
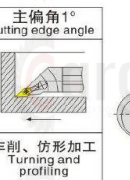

DESIGNATION	Dimension(mm)						Accessories				
	DMIN	∅d	f	L	H	α°	SHIM	Shim pin	clamp	screw clamp	Wrench
S25 MVXNR/L M16	32	25	17	200	24	12	MV1603	CTM513	HL2414	ML0625	L2.5.L3.0
S32 MVXNR/L M16	42	32	23	250	30	17					
S40 MVXNR/L M16	50	40	27	300	38	15					

TNMG Internal Tool Holder

■ MTUNR/L

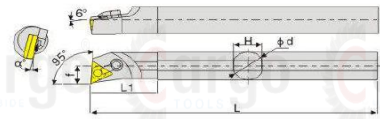

DESIGNATION	Dimension(mm)						Accessories					
	DMIN	φd	f	L	H	α°	SHIM	Shim pin	clamp	screw clamp	Wrench	
S20 MTUNR/L M16	25	20	13	180	13	15	MT1603	CTM510	HL1810	MLO620	L2.0,L2.5	
S25 MTUNR/L M16	32	25	17	200	24	12						
S32 MTUNR/L M16	41	32	22.5	250	30	17			CTM513	HL1814		MLO625
S40 MTUNR/L M16	50	40	26.5	300	38	15						

■ MTQNR/L

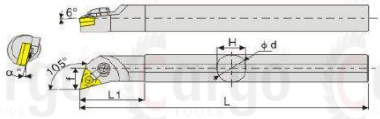
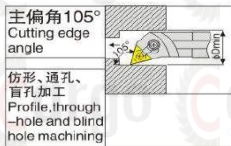

DESIGNATION	Dimension(mm)						Accessories					
	DMIN	φd	f	L	H	α°	SHIM	Shim pin	clamp	screw clamp	Wrench	
S20 MTQNR/L M16	25	20	13	180	13	15	MT1603	CTM510	HL1810	MLO620	L2.0,L2.5	
S25 MTQNR/L M16	32	25	17	200	24	12						
S32 MTQNR/L M16	41	32	22.5	250	30	17			CTM513	HL1814		MLO625
S40 MTQNR/L M16	50	40	26.5	300	38	15						

■ MTWNR/L

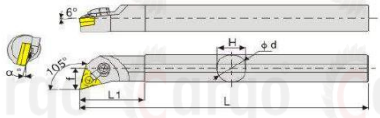
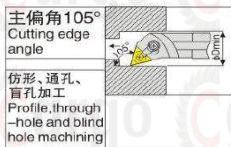

DESIGNATION	Dimension(mm)						Accessories				
	DMIN	φd	f	L	H	α°	SHIM	Shim pin	clamp	screw clamp	Wrench
S20 MTQNR/L M16	27	20	13	180	19	15	MT1603	CTM510	HL1810	MLO620	L2.0,L2.5
S25 MTQNR/L M16	34	25	17	200	24	12					
S32 MTQNR/L M16	42	32	20	250	30	17					

CCMT Internal Tool Holder

■SCLCL/R

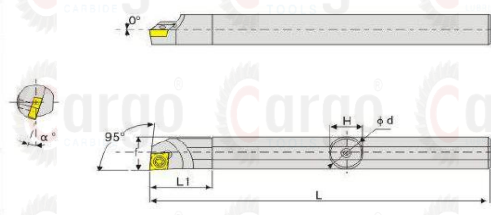

DESIGNATION	Dimension(mm)						INSERT SIZE	Accessories	
	D _{MIN}	φ _d	f	L	H	α°		SCREW	WRENCH
S08 SCLCR/L 06	10	8	5.5	125	7	13	CCMT 06	M2.5 X 6	T-8
S10 SCLCR/L 06	13	10	7	125	9	12			
S12 SCLCR/L 06	16	12	9	150	11	10			
S12 SCLCR/L 09	16	12	9	150	11	12			
S16 SCLCR/L 09	20	16	11	160	15	10	CCMT 09	M3.5 X 9	T-15
S20 SCLCR/L 09	24	20	13	180	19	8			
S25 SCLCR/L 09	26	25	17	200	24	6			
S32 SCLCR/L 09	32	32	22	250	30	4			
S25 SCLCR/L 12	26	25	17	200	24	8	CCMT 12	M5 X 12	T-20
S32 SCLCR/L 12	33	32	22	250	30	6			
S40 SCLCR/L 12	41	40	27	300	38	4			

■SCKCL/R

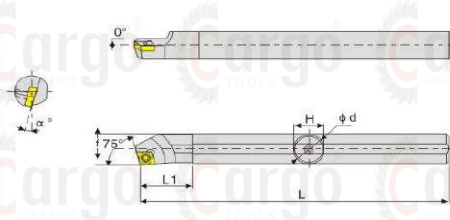
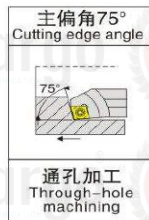

DESIGNATION	Dimension(mm)						INSERT SIZE	Accessories	
	D _{MIN}	φ _d	f	L	H	α°		SCREW	WRENCH
S08 SCKCR/L 06	10	8	5.5	125	7	13	CCMT 06	M2.5 X 6	T-8
S10 SCKCR/L 06	13	10	7	125	9	12			
S12 SCKCR/L 06	16	12	5.5	150	11	10			
S12 SCKCR/L 09	16	12	9	150	11	12			
S16 SCKCR/L 09	20	16	11	160	15	10	CCMT 09	M3.5 X 9	T-15
S20 SCKCR/L 09	24	20	13	180	19	8			
S25 SCKCR/L 09	26	25	17	200	24	6			
S32 SCKCR/L 09	32	32	22	250	30	4			
S25 SCKCR/L 12	26	25	17	200	24	8	CCMT 12	M5 X 12	T-20
S32 SCKCR/L 12	33	32	22	250	30	6			
S40 SCKCR/L 12	41	40	27	300	38	4			

SCZCL/R

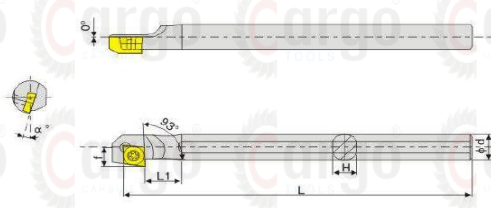

DESIGNATION	Dimension(mm)						INSERT SIZE	Accessories	
	D _{MIN}	φ _d	f	L	H	α°		SCREW	WRENCH
S08 SCZCR/L 06	10	8	6.5	125	7	13	CCMT 06	M2.5 X 6	T-8
S10 SCZCR/L 06	13	10	7.5	125	9	12			
S12 SCZCR/L 06	16	12	8.5	150	11	10			
S12 SCZCR/L 09	16	12	9	150	11	12	CCMT 09	M3.5 X 9	T-15
S16 SCZCR/L 09	20	16	11	160	15	10			
S20 SCZCR/L 09	24	20	13	180	19	8			
S25 SCZCR/L 09	26	25	17	200	24	6			
S32 SCZCR/L 09	32	32	22	250	30	4			

SCLCR/R (STEP BORING TOOL)

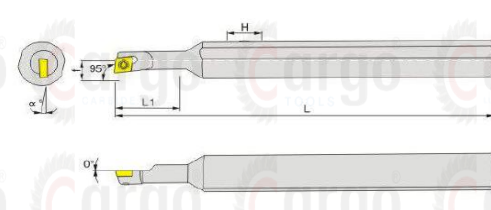
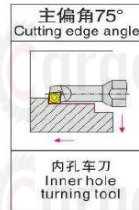

DESIGNATION	Dimension(mm)						INSERT SIZE	Accessories	
	D _{MIN}	φ _d	f	L	L ₁	α°		SCREW	WRENCH
S08/16 SCLCR/L 06	11	16	5.5	125	15	13	CCMT 06	M2.5 X 6	T-8
S10/16 SCLCR/L 06	12	16	6	125	15	12			
S12/16 SCLCR/L 06	14	16	7	150	15	10			

SCMT Internal Tool Holder

SSSCR/L

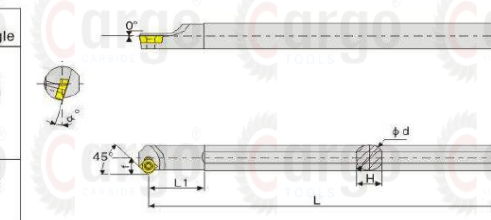
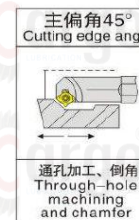

DESIGNATION	Dimension(mm)						INSERT SIZE	Accessories	
	D _{MIN}	φ _d	f	L	H	α°		SCREW	WRENCH
S12 SSSCR/L M09	16	12	8.5	150	11	12	SCMT 09T3	M4X10	T15
S16 SSSCR/L M09	22	16	11	160	15	10			
S20 SSSCR/L M12	26	20	13	180	19	8	SCMT 1204	M4X10	T-15
S25 SSSCR/L M12	31	25	16	200	24	6			
S32 SSSCR/L M12	38	32	19	250	32	4			

DCMT Internal Tool Holder

SDQCR/L

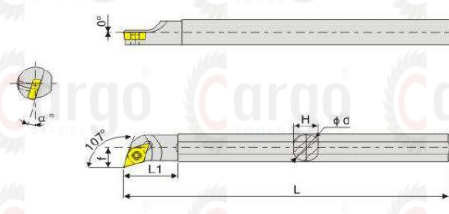

DESIGNATION	Dimension(mm)						INSERT SIZE	Accessories	
	D _{MIN}	φ _d	f	L	H	α°		SCREW	WRENCH
S10 SDQCR/L M07	13	10	7	125	9	10	DCMT 07	M2.5X6	T-8
S12 SDQCR/L M07	16	12	9	150	11	8			
S16 SDQCR/L M07	20	16	10.5	180	11	6			
S20 SDQCR/L M11	25	20	13	180	19	6	DCMT 11	M3.5 X 10	T-15
S25 SDQCR/L M11	32	25	16	200	24	4			
S32 SDQCR/L M11	39	32	20	250	30	4			

SDUCR/L

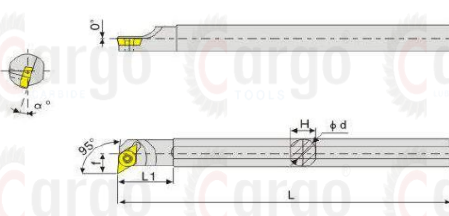

DESIGNATION	Dimension(mm)						INSERT SIZE	Accessories	
	D _{MIN}	φ _d	f	L	H	α°		SCREW	WRENCH
S10 SDUCR/L M07	15	10	8	125	9	10	DCMT 07	M2.5X6	T-8
S12 SDUCR/L M07	17	12	9	150	11	8			
S16 SDUCR/L M07	22	16	10.5	180	11	6			
S20 SDUCR/L M11	23	20	13	180	19	6	DCMT 11	M 3.5 X 10	T-15
S25 SDUCR/L M11	29	25	16	200	24	4			
S32 SDUCR/L M11	38	32	20	250	30	4			
S40 SDUCR/L M11	45	40	25	300	38	2			
S50 SDUCR/L M11	60	50	31	350	48	0			

SDWCR/L

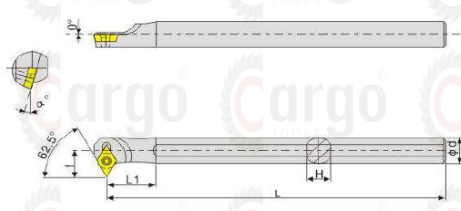
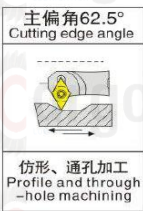

DESIGNATION	Dimension(mm)						INSERT SIZE	Accessories	
	D _{MIN}	φ _d	f	L	H	α°		SCREW	WRENCH
S12 SDWCR/L M07	17	12	10.5	150	11	10	DCMT 07	M2.5X6	T-8
S16 SDWCR/L M07	22	16	12.5	180	15	8			
S20 SDWCR/L M11	23	20	14.5	180	18	6	DCMT 11	M3.5 X 10	T-15
S25 SWUCR/L M11	29	25	17	200	23	4			
S32 SDWCR/L M11	38	32	22	250	30	2			

SDZCR/L

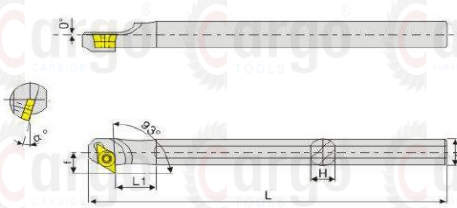

DESIGNATION	Dimension(mm)						INSERT SIZE	Accessories	
	DMIN	φd	f	L	H	α°		SCREW	WRENCH
S10 SDZCR/L M07	15	10	8	125	9	12	DCMT 07	M2.5X6	T-8
S12 SDZCR/L M07	17	12	9	150	11	10			
S16 SDZCR/L M07	22	16	11	180	15	8			
S20 SDZCR/L M11	23	20	14	180	19	8	DCMT 11	M3.5X9	T-15
S25 SDZCR/L M11	29	25	16.5	200	24	6			
S32 SDZCR/L M11	38	32	20	250	30	4			

SDXCR/L

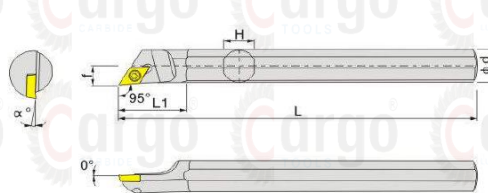
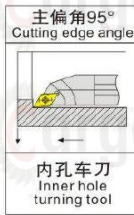

DESIGNATION	Dimension(mm)						INSERT SIZE	Accessories	
	DMIN	φd	f	L	L1	α°		SCREW	WRENCH
S10 SDXCR/L M07	13	10	8	125	25	10	DCMT 07	M2.5X6	T-8
S12 SDXCR/L M07	16	12	9	150	30	8			
S16 SDXCR/L M07	20	16	10.5	180	30	6			
S20 SDXCR/L M11	25	20	13	180	40	6	DCMT 11	M3.5X9	T-15
S25 SDXCR/L M11	32	25	16	200	40	4			
S32 SDXCR/L M11	40	32	20	250	45	4			

TCMT Internal Tool Holder

STUCR/L

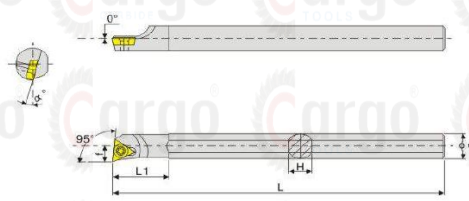

DESIGNATION	Dimension(mm)							INSERT SIZE	Accessories	
	DMIN	φd	f	L	H	α°	SCREW		WRENCH	
S08 STUCR/L M09	9	8	5.5	125	7	15	TCMT 09	M2.2X5	T-6	
S10 STUCR/L M09	11	10	6.5	125	9	12				
S10 STUCR/L M11	11	10	6	125	9	12	TCMT 11	M2.5X6	T-8	
S12 STUCR/L M11	13	12	7	150	11	10				
S16 STUCR/L M11	17	16	9	160	15	8	TCMT 16	M3.5X9	T-15	
S20 STUCR/L M11	21	20	11	180	19	6				
S20 STUCR/L M16	24	20	13	180	19	6				
S25 STUCR/L M16	26	25	14	200	24	6				
S32 STUCR/L M16	33	32	17.5	250	32	4				
S40 STUCR/L M16	42	40	23.5	300	38	4				
S50 STUCR/L M16	51	50	26.5	350	48	4				

STFCR/L

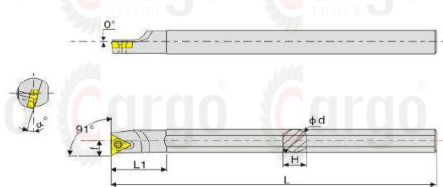
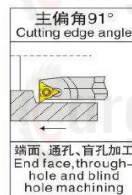

DESIGNATION	Dimension(mm)							INSERT SIZE	Accessories	
	DMIN	φd	f	L	H	α°	SCREW		WRENCH	
S08 STFCR/L M09	9	8	5.5	125	7	15	TCMT 09	M2.2X5	T-6	
S10 STFCR/L M09	11	10	6.5	125	9	12				
S12 STFCR/L M11	13	12	7	150	11	10	TCMT 11	M 2.5X6	T-8	
S16 STFCR/L M11	17	16	9	160	15	8				
S20 STFCR/L M11	21	20	11	180	19	6	TCMT 16	M3.5 X 9	T-15	
S20 STFCR/L M16	24	20	13	180	19	6				
S25 STFCR/L M16	26	25	14	200	24	6				
S32 STFCR/L M16	33	32	17.5	250	32	4				
S40 STFCR/L M16	43	40	23.5	300	38	4				
S50 STFCR/L M16	51	50	26.5	350	48	4				

STWCR/L

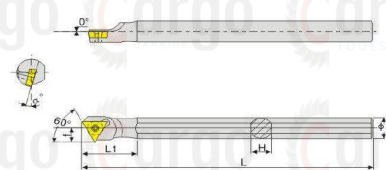

DESIGNATION	Dimension(mm)							INSERT SIZE	Accessories	
	DMIN	φd	f	L	H	α°	SCREW		WRENCH	
S08 STWCR/L M09	11	8	5.5	125	7	12	TCMT 09	M2.2X5	T-6	
S10 STWCR/L M09	14	10	8	125	9	10				
S12 STWCR/L M11	16	12	9	150	11	8	TCMT 11	M 2.5X6	T-8	
S16 STWCR/L M11	20	16	11	160	15	6				
S20 STWCR/L M11	25	20	13	180	19	4	TCMT 16	M4X10	T15	
S25 STWCR/L M16	32	25	17	200	24	6				

VBMT Internal Tool Holder

SVJUR/L

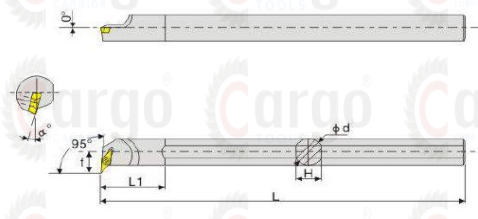

DESIGNATION	Dimension(mm)						INSERT SIZE	Accessories	
	DMIN	φd	f	L	H	α°		SCREW	WRENCH
S10 SVJUR M11	12	10	6	125	9	13	VBMT 11	M 2.5X6	T-8
S12 SVJUR M11	14	12	7	150	11	10			
S16 SVJUR M11	22	16	9.5	180	15	8			
S20 SVJUR M11	27	20	14	180	19	10	VBMT 16	M4X10	T-15
S25 SVJUR M16	35	25	19	200	24	8			
S32 SVJUR M16	42	32	22	250	30	10			
S40 SVJUR M16	51	40	27	300	38	8			

SVQCR/L

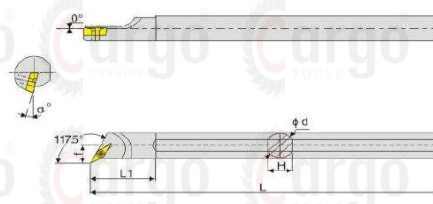
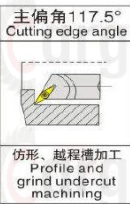

DESIGNATION	Dimension(mm)						INSERT SIZE	Accessories	
	DMIN	φd	f	L	H	α°		SCREW	WRENCH
S16 SVQBR M11	22	16	11.5	180	15	10	VBMT 11	M 2.5X6	T-8
S20 SVQBR M11	27	20	14	180	18	8			
S16 SVQBR M16	22	16	11.5	180	15	10	VBMT 16	M 3.5X9	T-15
S20 SVQBR M16	27	20	14	180	18	8			
S25 SVQBR M16	32	25	17	200	23	6			
S32 SVQBR M16	41	32	22.5	250	30	8			
S40 SVQBR M16	50	40	27	300	38	6			
S50 SVQBR M16	61	50	32	350	48	4			

SVXCR/L

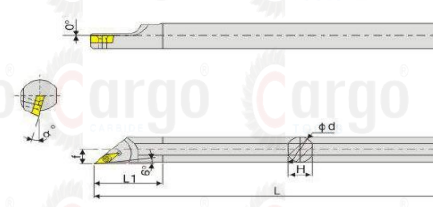
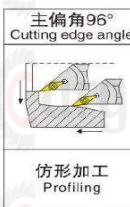

DESIGNATION	Dimension(mm)						INSERT SIZE	Accessories	
	DMIN	φd	f	L	H	α°		SCREW	WRENCH
S16 SVXBR M11	19	16	11.5	180	15	10	VBMT 11	M 2.5X6	T-8
S20 SVXBR M11	23	20	14	180	18	8			
S16 SVXBR M16	19	16	11.5	180	15	10	VBMT 16	M 3.5X9	T-15
S20 SVXBR M16	23	20	14	180	18	8			
S25 SVXBR M16	30	25	17	200	23	6			
S32 SVXBR M16	38	32	22.5	250	30	8			
S40 SVXBR M16	47	40	27	300	38	6			
S50 SVXBR M16	60	50	32	350	48	4			

SVZCR/L

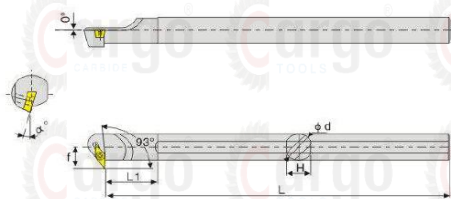

DESIGNATION	Dimension(mm)						INSERT SIZE	Accessories	
	D _{MIN}	Ød	f	L	H	α°		SCREW	WRENCH
S16 SVXBR M11	19	16	11.5	180	15	10	VBMT 11	M 2.5X6	T-8
S20 SVXBR M11	24	20	14	180	18	8			
S25 SVXBR M16	33	25	19.5	200	23	6			
S32 SVXBR M16	39	32	23.5	250	30	8	VBMT 16	M 3.5X9	T-15
S40 SVXBR M16	47	40	27	300	38	6			

WBMT Internal Tool Holder

SWUBR/L

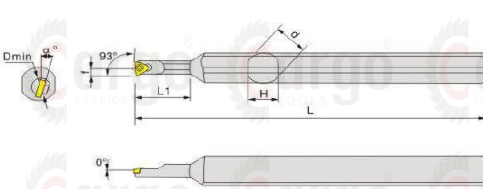
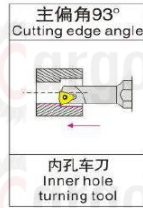

DESIGNATION	Dimension(mm)						INSERT SIZE	Accessories	
	D _{MIN}	Ød	f	L	H	α°		SCREW	WRENCH
S06 SWUBR/L 06	7	6	3.5	100	5.4	15	WBMT 06	M2.2X6	T6
S08-05 SWUBR/L 06	6	8	3	100	7	15			
S10-05 SWUBR/L 06	6	10	3	125	9	15			

SER/L

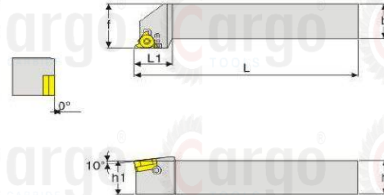

DESIGNATION	Dimension(mm)						SPARE			INSERT SIZE
	h	b	L	f	h1	L1	SHIM	SCREW	WRENCH	
SER/L 12X12 M16	12	12	100	16	12	20	STM1603	M3.5X12	T15	16 ER/IL
SER/L 16X16 M16	16	16	100	20	16	22				
SER/L 20X20 M16	20	20	125	25	20	22				
SER/L 25X25 M16	25	25	150	32	25	22				
SER/L 32X32 M16	32	32	170	40	32	22				

Threading Internal Tool holder

SINR/L

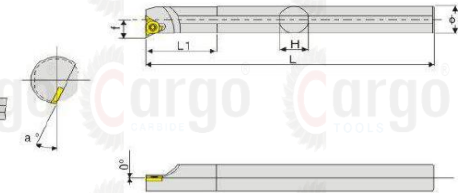
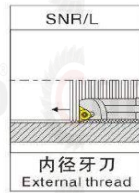

DESIGNATION	Dimension(mm)						SPARE			INSERT SIZE
	D _{MIN}	Ød	H	L	f	α°	SHIM	SCREW	WRENCH	
SINR 0010 K11	13	10	9	125	7.2	15	STM1603	M2.5X6	T8	11 IR
SINR 0012 K11	15	12	11	150	8.5	15				
SINR/L 0013 M16	16	16	15	150	10.2	17				
SINR/L 0016 M16	19	16	15	150	11.7	15				
SINR/L 0020 M16	24	20	19	180	13.7	21				
SINR/L 0025 M16	29	25	24	200	16.2	21	STM1603	M3.5X12	T15	16 IR/EL
SINR/L 0032 M16	36	32	30	250	19.7	15				
SINR/L 0040 M16	44	40	38	300	23.7	15				
SINR/L 0050 M16	54	50	48	350	28.7	15				

GROOVING HOLDER

■ MGEHR/L

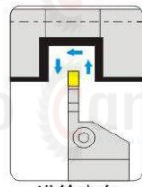

进给方向
Feed direction

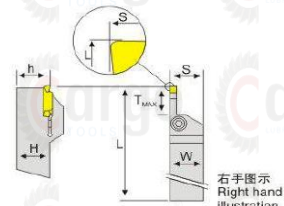

DESIGNATION	Dimension(mm)					INSERT SIZE	SPARE	
	H=h	W	L	S	T-MAX		SCREW	WRENCH
MGEHR/L 16X16 1.5MM	16	16	100	16.25	T _{max} -10/12/15	MGMN 150G	M5X16	L4.0
MGEHR/L 20X20 1.5MM	20	20	125	20.25	T _{max} -10/12/15			
MGEHR/L 25X25 1.5MM	25	25	150	25.25	T _{max} -10/12/15/18/20/25	MGMN 200G	M6X20	L5.0
MGEHR/L 12X12 2MM	12	12	100	14.25	T _{max} -10/12			
MGEHR/L 16X16 2MM	16	16	100	16.25	T _{max} -10/12/15	MGMN 200G	M6X20	L5.0
MGEHR/L 20X20 2MM	20	20	125	20.25	T _{max} -10/12/15/18/20			
MGEHR/L 25X25 2MM	25	25	150	25.25	T _{max} -10/12/15/18/20/25	MGMN 250M	M5X16	L4.0
MGEHR/L 20X20 2.5MM	20	20	125	20.25	T _{max} -10/12/15/18/20			
MGEHR/L 25X25 2.5MM	25	25	150	25.25	T _{max} -10/12/15/18/20/25	MGMN 300M	M6X25	L5.0
MGEHR/L 16X16 3MM	16	16	100	16.25	T _{max} -10/12/15			
MGEHR/L 20X20 3MM	20	20	125	20.25	T _{max} -10/12/15/18/20	MGMN 300M	M6X25	L5.0
MGEHR/L 25X25 3MM	25	25	150	25.25	T _{max} -10/12/15/18/20/25			
MGEHR/L 32X32 3MM	32	32	170	32.4	T _{max} -20/25/30	MGMN 400M	M6X25	L5.0
MGEHR/L 20X20 4MM	20	20	125	20.25	T _{max} -10/12/15/18/20			
MGEHR/L 25X25 4MM	25	25	150	25.25	T _{max} -10/12/15/18/20/25	MGMN 500M	M6X25	L5.0
MGEHR/L 32X32 4MM	32	32	170	32.4	T _{max} -20/25/30			
MGEHR/L 20X20 5MM	20	20	125	20.5	T _{max} -15/18/20	MGMN 500M	M6X25	L5.0
MGEHR/L 25X25 5MM	25	25	150	25.5	T _{max} -15/18/20/25/30			
MGEHR/L 32X32 5MM	32	32	170	32.4	T _{max} -20/25/30	MGMN 600M	M6X25	L5.0
MGEHR/L 20X20 6MM	20	20	125	20.6	T _{max} -15/18/20			
MGEHR/L 25X25 6MM	25	25	150	25.6	T _{max} -15/18/20/25/30	MGMN 600M	M6X25	L5.0
MGEHR/L 32X32 6MM	32	32	170	32.6	T _{max} -20/25/30/35			
MGEHR/L 25X25 8MM	25	25	150	26.1	T _{max} -25/30/35	MGMN 800M	M6X25	L5.0
MGEHR/L 32X32 8MM	32	32	170	33.1	T _{max} -30/35			

Grooving Internal Tool holder

MGHR/L

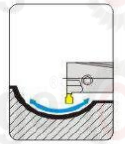

进给方向
Feed direction

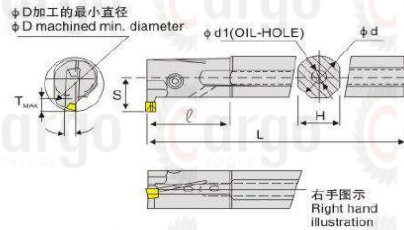

DESIGNATION	Dimension(mm)						INSERT SIZE	SPARE	
	D	d	L	l	H	S		SCREW	WRENCH
S16 MGVR/L 1.5	20	16	125	35	15	11.3	MGMN 150G	M5X3	L2.5
S20 MGVR/L 1.5	25	20	150	45	18	13.1			L4.0
S25 MGVR/L 1.5	29	25	200	45	23	16.2	MGMN 200G	M5X3	L2.5
S16 MGVR/L 2	20	16	125	35	15	12.4			L4.0
S20 MGVR/L 2	25	20	150	45	18	14	MGMN 250M	M5X3	L2.5
S25 MGVR/L 2	29	25	200	45	23	17.2			L4.0
S16 MGVR/L 2.5	20	16	125	35	15	12.5	MGMN 300M	M5X3	L2.5
S20 MGVR/L 2.5	25	20	150	45	18	15.1			L4.0
S25 MGVR/L 2.5	29	25	200	45	23	18.2	MGMN 400M	M5X7	L4.0
S20 MGVR/L 3	25	20	150	45	18	15.6			
S25 MGVR/L 3	31	25	200	45	23	18.9	MGMN 500M	M5X7	L4.0
S32 MGVR/L 3	37	32	250	65	30	21.5			
S20 MGVR/L 4	25	20	150	45	18	15.6	MGMN 500M	M5X7	L4.0
S25 MGVR/L 4	31	25	200	45	23	18.9			
S32 MGVR/L 4	37	32	250	65	30	21.5	MGMN 500M	M5X7	L4.0
S25 MGVR/L 5	31	25	200	45	23	19.4			
S32 MGVR/L 5	37	32	250	65	30	21.5			

SNGR/L

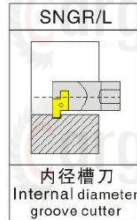

内径槽刀
Internal diameter
groove cutter

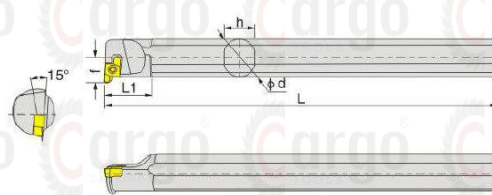

DESIGNATION	Dimension(mm)						INSERT SIZE	SPARE	
	T-max	d	f	LI	L	H		SCREW	WRENCH
S08 SNGR/L 06	2	8	4.7	15	100	7	6 GR	M2.2X4	T7
S08 SNGR/L 07	2	8	5.8	15	100	7	7 GR		
S10 SNGR/L 07	2	10	6.8	15	125	8	8 GR	M2.5X6	T8
S12 SNGR/L 08	3.5	12	8.6	20	150	11			
S16 SNGR/L 08	3.5	16	11.6	20	180	14.8	9 GR	M2.5X6	T8
S20 SNGR/L 08	3.5	20	13.6	20	200	18.4			

BT TAPER ER COLLET CHUCK

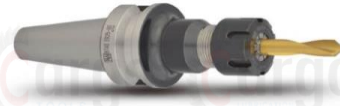
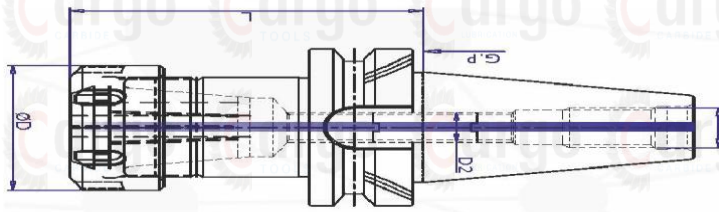

BT30	NUT DIA D	LONG (L)	COLLET TYPE	CLAMPING RANGE	DI
ER16-70/100/150	28	70/100/150	ER16	0.5-10	M12
ER20-70/100/150	35	70/100/150	ER20	1.0-12	M12
ER25-70/100/150	42	70/100/150	ER25	1.0-16	M12
ER32-70/100/150	50	70/100/150	ER32	2.0-20	M12
ER40-80/100/150	63	70/100/150	ER40	2.0-26	M12

BT40	NUT DIA D	LONG (L)	COLLET TYPE	CLAMPING RANGE	DI
ER16-70/100/150	32	70/100/150	ER16	0.5-10	M16
ER20-70/100/150	35	70/100/150	ER20	1.0-12	M16
ER25-70/100/150	42	70/100/150	ER25	1.0-16	M16
ER32-70/100/150	50	70/100/150	ER32	2.0-20	M16
ER40-80/100/150	63	70/100/150	ER40	2.0-26	M16

BT40	NUT DIA D	LONG (L)	COLLET TYPE	CLAMPING RANGE	DI
ER16-70/100/150	32	70/100/150	ER16	0.5-10	M24
ER20-70/100/150	35	70/100/150	ER20	1.0-12	M24
ER25-70/100/150	42	70/100/150	ER25	1.0-16	M24
ER32-70/100/150	50	70/100/150	ER32	2.0-20	M24
ER40-80/100/150	63	70/100/150	ER40	2.0-26	M24

SK TAPER ER COLLET CHUCK

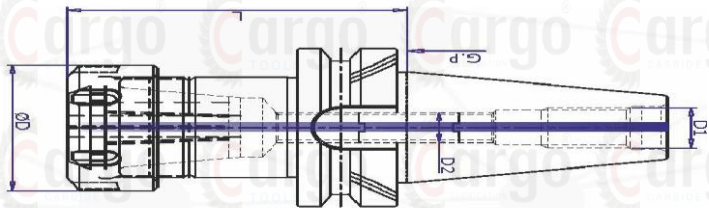

SK40	NUT DIA D	LONG (L)	COLLET TYPE	CLAMPING RANGE	DI
ER16-70/100/150	28	70/100/150	ER16	0.5-10	M16
ER20-70/100/150	35	70/100/150	ER20	1.0-12	M16
ER25-70/100/150	42	70/100/150	ER25	1.0-16	M16
ER32-70/100/150	50	70/100/150	ER32	2.0-20	M16
ER40-80/100/150	63	70/100/150	ER40	2.0-26	M16

SK50	NUT DIA D	LONG (L)	COLLET TYPE	CLAMPING RANGE	DI
ER16-70/100/150	32	70/100/150	ER16	0.5-10	M24
ER20-70/100/150	35	70/100/150	ER20	1.0-12	M24
ER25-70/100/150	42	70/100/150	ER25	1.0-16	M24
ER32-70/100/150	50	70/100/150	ER32	2.0-20	M24
ER40-80/100/150	63	70/100/150	ER40	2.0-26	M24

CAT TAPER ER COLLET CHUCK

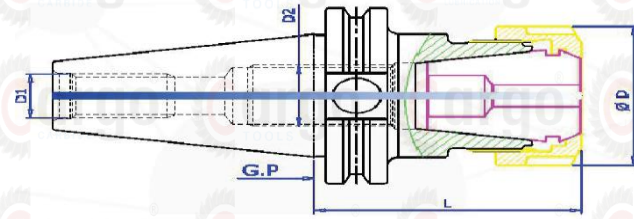

CAT40	NUT DIA D	LONG (L)	COLLET TYPE	CLAMPING RANGE	DI
ER16-2.76" / 4" / 6"	32	2.76" / 4" / 6"	ER16	0.0156"-0.375"	5/8"-II
ER20-2.76" / 4" / 6"	35	2.76" / 4" / 6"	ER20	0.0625"-0.5"	5/8"-II
ER25-2.76" / 4" / 6"	42	2.76" / 4" / 6"	ER25	0.0625"-0.625"	5/8"-II
ER32-2.76" / 4" / 6" / 8"	50	2.76" / 4" / 6" / 8"	ER32	0.125"-0.75"	5/8"-II
ER40-2.76" / 4" / 6" / 8"	63	2.76" / 4" / 6" / 8"	ER40	0.125"-1.00"	5/8"-II
CAT50	NUT DIA D	LONG (L)	COLLET TYPE	CLAMPING RANGE	DI
ER16-2.76" / 4" / 6"	32	2.76" / 4" / 6"	ER16	0.0156"-0.375"	1"-8
ER20-2.76" / 4" / 6"	35	2.76" / 4" / 6"	ER20	0.0625"-0.5"	1"-9
ER25-2.76" / 4" / 6"	42	2.76" / 4" / 6"	ER25	0.0625"-0.625"	1"-10
ER32-2.76" / 4" / 6" / 8"	50	2.76" / 4" / 6" / 8"	ER32	0.125"-0.75"	1"-11
ER40-2.76" / 4" / 6"	63	2.76" / 4" / 6" / 8"	ER40	0.125"-1.00"	1"-12

HSK TAPER ER COLLET CHUCK

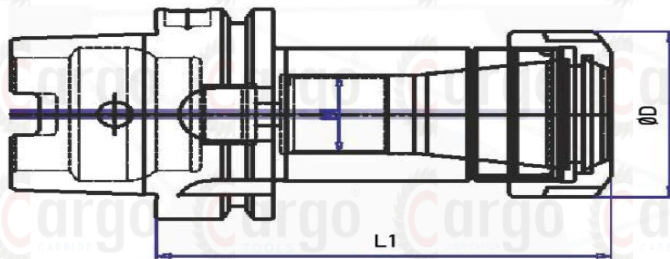

MODEL NO.	NUT DIA D	LONG (L1)	COLLET TYPE	CLAMPING RANGE	M
A50-ER16-60/100	28	60/100	ER16	0.5-1.0	M10XIP
A50-ER20-70/100	35	70/100	ER20	1.0-12	M10XIP
A50-ER25-70/100	42	70/100	ER25	1.0-16	M18XIP
A50-ER32-70/100	50	70/100	ER32	2.0-20	M22XI.5P
A50-ER40-80/100	63	80/100	ER40	3.0-26	M30XI.5P
A63-ER16-100/160	28	100/160	ER16	0.5-1.0	M10XIP
A63-ER20-100/160	35	100/160	ER20	1.0-12	M10XIP
A63-ER25-100/160	42	100/160	ER25	1.0-16	M18XIP
A63-ER32-100/160	50	100/160	ER32	2.0-20	M22XI.5P
A63-ER40-120/160	63	120/160	ER40	3.0-26	M30XI.5P
A100-ER25-100/160	42	100/160	ER25	1.0-16	M18XIP
A100-ER32-100/160	50	100/160	ER32	2.0-20	M22XI.5P
A100-ER40-120/160	63	120/160	ER40	3.0-26	M30XI.5P

ISO TAPER ER COLLET CHUCK

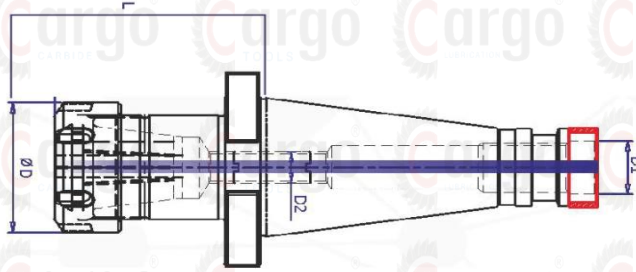

MODEL NO.	NUT DIA D	D1	D2	LONG (L)	CLAMPING RANGE	COLLET TYPE
BT30-ER16-50	28	M12	M10XP	50	0.5-1.0	ER16
BT30-ER20-50	34		M10XP	50	1.0-12	ER20
BT30-ER25-50	42		M18XP	50	1.0-16	ER25
BT30-ER32-50	50	M16	M30XI.5P	50	2.0-20	ER32
BT40-ER16-60	28		M10XP	60	0.5-1.0	ER16
BT40-ER20-60	34		M10XP	60	1.0-12	ER20
BT40-ER25-60	42		M18XP	60	1.0-16	ER25
BT40-ER32-70	50	M24	M22XI.5P	70	2.0-20	ER32
BT40-ER40-80	63		M30XI.5P	80	3.0-26	ER40
BT50-ER25-60	42		M18XP	60	1.0-16	ER25
BT50-ER32-70	50	M24	M22XI.5P	70	2.0-20	ER32
BT50-ER40-80	63		M30XI.5P	80	3.0-26	ER40
BT50-ER50-100	78		M30XI.5P	100	3.0-26	ER40

BT TAPER FACEMILL HOLDER

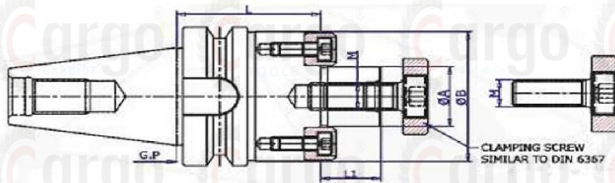

BT30/40/50	A	L	LI	B	M
FMH-16-40/100/150	16	40/100/150	17	38	M8
FMH-22-45/100/150/200/250	22	45/100/150/200/250	19	48	M10
FMH-27-45/100/150	27	45/100/150	21	58	M12
FMH-32-60/100/150	32	60/100/150	24	78	M16
FMH-40-45/100/150	40	45/100/150	27	82	M20

SK TAPER FACEMILL HOLDER

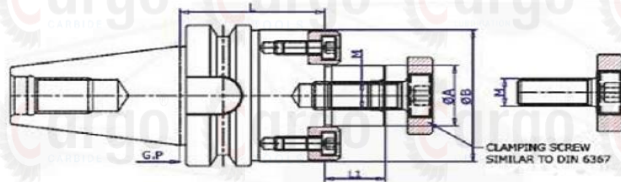

SK 30/40/50	A	L	LI	B	M
FMH-16-40/100/150	16	40/100/150	17	38	M8
FMH-22-45/100/150/200/250	22	45/100/150/200/250	19	48	M10
FMH-27-45/100/150	27	45/100/150	21	58	M12
FMH-32-60/100/150	32	60/100/150	24	78	M16
FMH-40-45/100/150	40	45/100/150	27	82	M20

CAT TAPER FACEMILL HOLDER

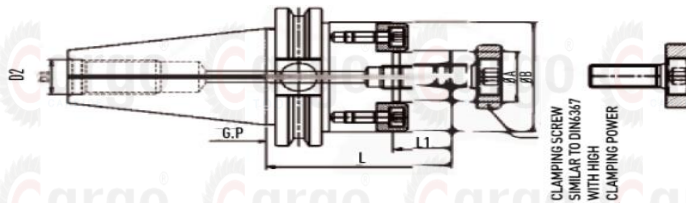

CAT40/50	A	B	L	LI	DI
3/4"-13/4", 4", 6"	3/4"	2.0"	1.75"/4"/6"	0.687"	5/8"-II
1.0"-2", 4", 6"	1.0"	2.375"	2"/4"/6"	0.687"	5/8"-II
1 1/4"-2", 4", 6"	1 1/4"	2.875"	2"/4"/6"	0.687"	5/8"-II
1 1/2"-2", 4", 6"	1 1/2"	3.75"	2"/4"/6"	0.938"	5/8"-II

HSK TAPER FACEMILL HOLDER

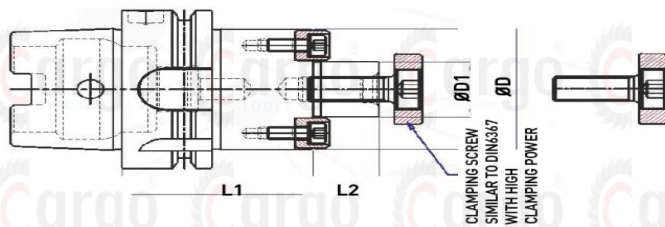

A50/63/100	D1	LI	D	L2
FMH16-45/100/160	16	45/100/160	38	17
FMH22-50/100/160	22	50/100/160	48	19
FMH27-55/100/160	27	55/100/160	58	21
FMH32-60/100/160	32	60/100/160	78	24
FMH40-65/100/160	40	65/100/160	88	27

BT TAPER SIDELOCK HOLDER

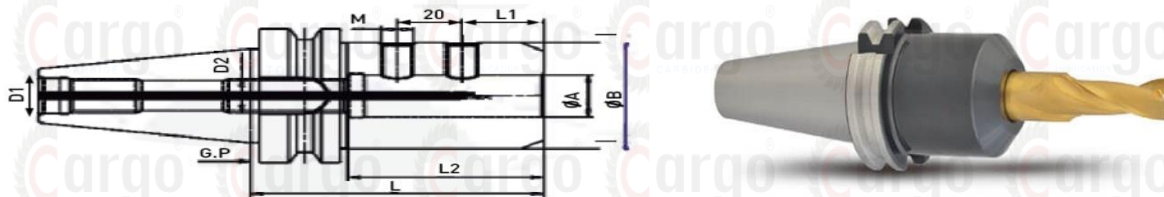

BT30/40/50	A	L	B	L1	L2	D2	M
SLA06-65L	6	65	20	15	35	M5	M6
SLA08-65L	8	65	24	15	40	M6	M8
SLA10-65L	10	65	30	16	44	M8	M10
SLA12-65L	12	65	35	20	44	M8	M10
SLA16-65/75L	16	65/75	40	23	52	M12	M10
SLA20-90/100L	20	90/100	50	25	70	M12	M10
SLA25-90/100/150	25	90/100/150	50	25	70	M12	M10
SLA32-90/100/150	32	90/100/150	60	30	70	M12	M10
SLA40-90/100/150	40	90/100/150	60	30	70	M12	M10
SLA50-75/100/150	50	75/100/150	90	40	70	M12	M12

HSK TAPER SIDELOCK HOLDER

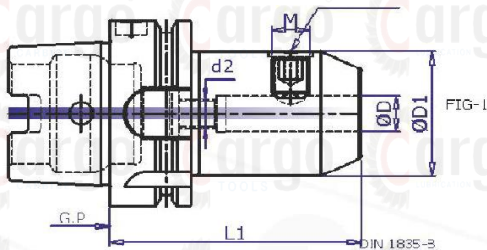

A50/63/100	D	L1	D1	M	D2
WN06-65/100/160	6	65/100/160	25	M6	M5
WN08-65/100/160	8	65/100/160	28	M8	M6
WN10-65/100/160	10	65/100/160	35	M10	M5
WN12-80/100/160	12	80/100/160	42	M12	M10
WN14-80/100/160	14	80/100/160	44	M12	M10
WN16-80/100/160	16	80/100/160	48	M14	M12
WN18-80/100/160	18	80/100/160	50	M14	M12
WN20-80/100/160	20	80/100/160	52	M16	M16

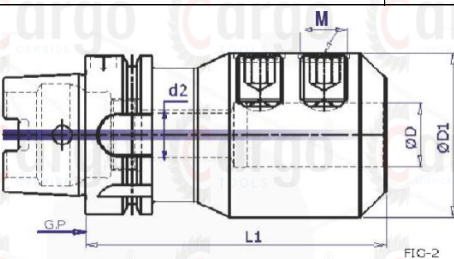

A50/63/100	D	L1	D1	M	D2
WN25-100/160	25	100/160	65	M18X2P	M20
WN32-100/120/160	32	100/120/160	72	M20X2P	M20
WN40-100/120/160	40	100/120/160	80	M20X2P	M20
WN50-130	50	130	100	M24X2P	M20

ISO TAPER SIDELOCK HOLDER

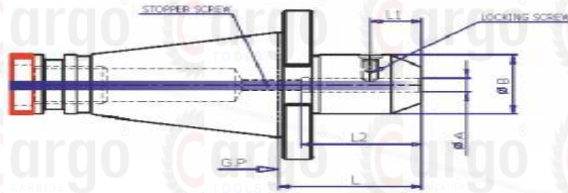

ISO 30/40/50	A	L	B	L1	L2	STOPPER SCREW	LOCKING SCREW
SLA06-65L	6	65	20	15	40	M5	M6
SLA08-65L	8	65	24	15	40	M6	M8
SLA10-65L	10	65	30	16	44	M8	M10
SLA12-65L	12	65	35	20	44	M8	M10
SLA16-65/75L	16	65/75	40	23	52	M12	M10

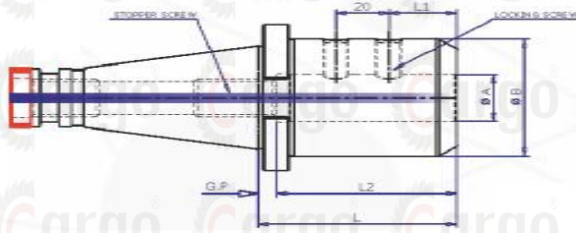

ISO 30/40/50	A	L	B	L1	L2	STOPPER SCREW	LOCKING SCREW
SLA20-90/100L	20	90/100	50	25	70	M6	M10
SLA25-90/100	25	90/100	50	25	70	M20	M10
SLA32-90/100	32	90/100	60	30	70	M12	M10
SLA40-90/100	40	90/100	60	30	70	M12	M10

BT MORSE TAPER HOLDER (MTA)

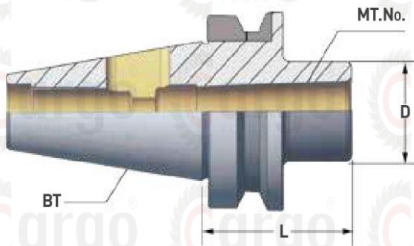

BT30/40/50	MT NO.	L	D
MTA01-50/100	MT-1	50/100	25
MTA02-50/125/140	MT-2	50/125/140	32
MTA03-70/140	MT-3	70/140	40
MTA04-95/180	MT-4	95/180	48
MTA05-120/220	MT-5	120/220	63

BT TAPER HYDRAULIC CHUCK

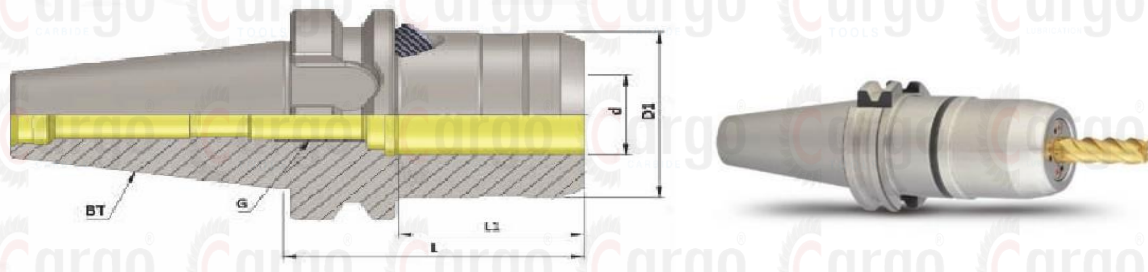

MODULE NO.	d	D1	G	L	L1
BT30 HYD12-69	12	42	M10	69	40
BT30 HYD20-90	20	50	M16	90	42
BT40 HYD12-58	12	42	M10	58	40
BT40 HYD20-72.5	20	50	M16	72.5	42
BT40 HYD32-90	32	72	M16	90	55
BT50 HYD12-69	12	42	M10	69	40
BT50 HYD20-83	20	50	M16	83	42
BT50 HYD32-90	32	72	M16	90	55
MODULE NO.	d	D1	G	L	L1
BT40 HYD6-90	6	42	M16	90	55
BT40 HYD8-90	8	42	M16	90	55
BT40 HYD10-90	10	42	M16	90	55
BT40 HYD14-90	14	42	M16	90	55
BT40 HYD16-90	16	42	M16	90	55
BT40 HYD18-90	18	50	M16	90	55
BT40 HYD25-90	25	65	M16	90	55

HYDRAULIC CHUCK SLEEVE

SLEEVE SIZE	RANGE
HC12	3,4,5,6,8
HC20	3,4,5,6,8,10,12,14,16
HC32	3,4,5,6,8,10,12,14,16,18,20,25

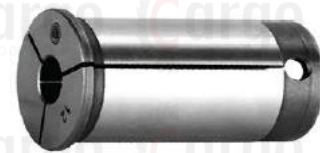

BT TAPER APU DRILL CHUCK

MODULE NO.	d	D	L
BT30-APU08-80	1-8	37	80
BT30-APU13-100	1-13	50	100
BT30-APU16-100	3-16	57	100
BT40-APU08-80	1-8	37	80
BT40-APU13-100	1-13	50	100
BT40-APU16-100	3-16	57	100
BT50-APU08-80	1-8	37	80
BT50-APU13-100	1-13	50	100
BT50-APU16-100	3-16	57	100

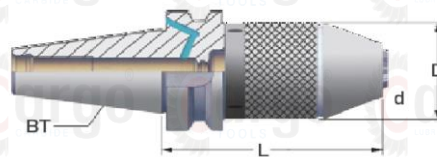

ER STRAIGHT SHANK HOLDER (BABY COLLET CHUCK)

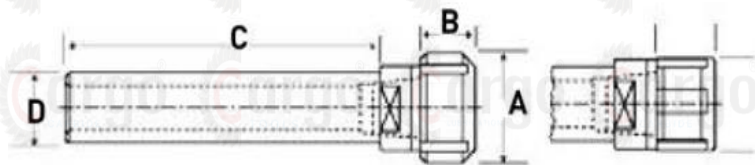

MODULE NO.	COLLET SIZE	SHANK DIA (D)	LENGTH (C)	NUT DIA (A)	NUT TYPE
C10-ER08-100	ER08	10	100	12	MINI
C12-ER11-100	ER11	12	100	16	MINI
C12-ER11-100	ER11	12	100	19	HEX
C16-ER11-100	ER11	16	100	16	MINI
C16-ER16-50	ER16	16	50	22	MINI
C16-ER16-100	ER16	16	100	22	MINI
C16-ER16-150	ER16	16	150	22	MINI
C16-ER11-100	ER11	16	100	19	HEX
C16-ER16-50	ER16	16	50	28	HEX
C16-ER16-100	ER16	16	100	28	HEX
C16-ER16-150	ER16	16	150	28	HEX
C20-ER16-50	ER16	20	50	28	HEX
C20-ER16-100	ER16	20	100	28	HEX
C20-ER16-150	ER16	20	150	28	HEX
C25-ER16-100	ER16	25	100	28	HEX
C25-ER16-150	ER16	25	150	28	HEX
C20-ER20-50	ER20	20	50	34	HEX
C20-ER20-100	ER20	20	100	34	HEX
C20-ER20-150	ER20	20	150	34	HEX
C25-ER25-100	ER25	25	100	42	UM (SPANNER)
C25-ER25-150	ER25	25	150	42	UM (SPANNER)
C25-ER25-100	ER25	25	100	42	UM (SPANNER)
C25-ER25-150	ER25	25	150	42	UM (SPANNER)
C32-ER25-100	ER25	32	100	42	UM (SPANNER)
C32-ER25-150	ER25	32	150	42	UM (SPANNER)
C32-ER32-100	ER32	32	100	50	UM (SPANNER)
C32-ER32-150	ER32	32	150	50	UM (SPANNER)
C40-ER32-100	ER32	40	100	50	UM (SPANNER)
C40-ER32-150	ER32	40	150	50	UM (SPANNER)
C40-ER40-100	ER40	40	100	63	UM (SPANNER)
C40-ER40-150	ER40	40	150	63	UM (SPANNER)

ER COLLET

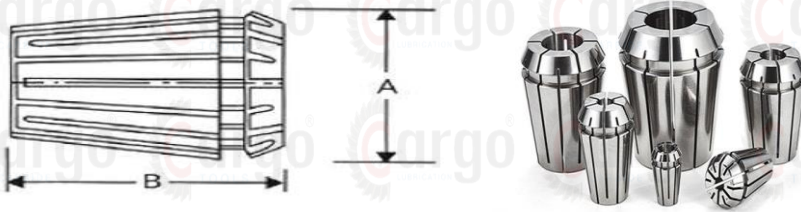

COLET SIZE	A	B	RANGE
ER08	8.5MM	13.5MM	1-5
ER11	11.5MM	18MM	1-7
ER16	17MM	27.5MM	1-10
ER20	21MM	31.5MM	2-13
ER25	26MM	34MM	2-16
ER32	33MM	40MM	2-20
ER40	41MM	46MM	2-26
ER50	52MM	60MM	12-34

ER SEALED COLLETS



COLET SIZE	A	B	RANGE
ERS11	11.3MM	18MM	3-7
ERS16	16.74MM	27.5MM	3-10
ERS20	20.74MM	31.5MM	3-13
ERS25	25.74MM	34MM	3-16
ERS32	32.74MM	40MM	3-20
ERS40	40.74MM	46MM	3-26
ERS50	51.50MM	60MM	12-34

ER TAP COLLETS



COLET SIZE	D	L	TAP SIZE
ERT16	16.74MM	27.5MM	M3-M8
ERT20	20.74MM	31.5MM	M3-M12
ERT25	25.74MM	34MM	M3-M14
ERT32	32.74MM	40MM	M3-M18
ERT40	40.74MM	46MM	M3-M27
ERT50	51.50MM	60MM	M6-M36

BT PULLSTUD

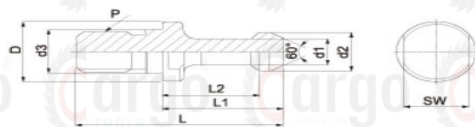

Model No.	Dimension(mm)		d1 (mm)	d2 (mm)	d3 (mm)	L (mm)	L1 (mm)	L2 (mm)	SW (mm)	Weight (Kgs)
	D (mm)									
BT30-45°	16.5		7	11	12.5	43	23	18	13	0.04
BT30-60°	16.5		7	11	12.5	43	23	18	13	0.04
BT30-90°	16.5		7	11	12.5	43	23	18	13	0.04
BT40-45°	23		10	15	17	60	35	28	19	0.11
BT40-60°	23		10	15	17	60	35	28	19	0.1
BT40-90°	23		10	15	17	60	35	28	19	0.1
BT50-45°	38		17	23	25	85	45	35	30	0.3
BT50-60°	38		17	23	25	85	45	35	30	0.3
BT50-90°	38		17	23	25	85	45	35	30	0.3

SPANNER

HEX SPANNER

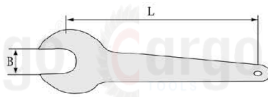

NUT SIZE	B	L
ER11-A	17	110
ER16-A	25	120
ER20-A	30	130

MINI SPANNER



NUT SIZE	B	L
ER08-M	7.5	70
ER11-M	11	90
ER16-M	15	110
ER20-M	19.5	120

UM SPANNER

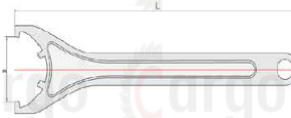

NUT SIZE	B	L
ER16-UM	26	180
ER20-UM	30	190
ER25-UM	37	210
ER32-UM	46.6	250
ER40-UM	58	290
ER50-UM	74	350



COLLET NUT

ER MINI NUT

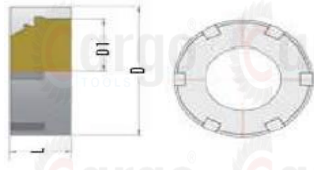

NUT SIZE	D	D1	L	T
ER08-M	12	10	10	M10X0.75
ER11-M	16	12	12	M13X0.75
ER16-M	22	17.2	18	M19X1
ER20-M	28	22.5	19	M24X1



ER HEX NUT

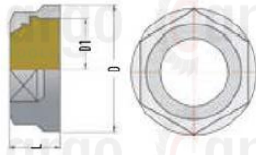

NUT SIZE	D	D1	L	T
ER11-A	19	17	11.3	M14X0.75
ER16-A	28	25	17.5	M22X1.5
ER20-A	34	30	19	M25X1.5



ER HEX NUT

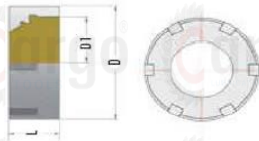

NUT SIZE	D	D1	L	T
ER16-UM	32	26	17	M22X1.5
ER20-UM	35	29	19	M25X1.5
ER25-UM	42	36	20	M32X1.5
ER32-UM	50	44	22.5	M40X1.5
ER40-UM	63	57	25.5	M50X1.5
ER50-UM	78	71	35.5	M64X2



ROUND INSERT CUTTER EMR (SIDE MILL CUTTER)

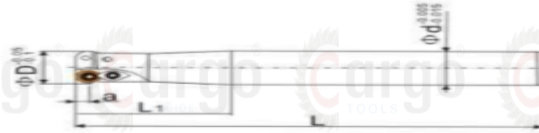

PRODUCT SIZE	DIMENSIONS				NO. OF EDGES	SUITABLE INSERT	SCREW	SCREW DRIVER
	BLADE DIA (D)	SHANK DIA (d)	L1	L				
EMR C10-4R10-120-IT	10	10	30	120	1	RPMT 0802 MO	M3×7	T10
EMR C12-4R12-130-IT	12	12	40	130	1		M3×7	T10
EMR C16-4R16-150-2T	16	16	50	150	2		M3×7	T10
EMR C16-4R16-200-2T	16	16	60	200	2		M3×7	T10
EMR C20-4R20-150-2T	20	20	50	150	2		M3×7	T10
EMR C20-4R20-200-2T	20	20	60	200	2		M3×7	T10
EMR C20-5R20-150-2T	20	19	40	150	2	RPMT 10T3 MO	M4×9	T15
EMR C20-5R20-200-2T	20	20	50	200	2		M4×9	T15
EMR C25-5R25-150-2T	25	25	50	150	2		M4×9	T15
EMR C25-5R25-200-2T	25	25	60	200	2		M4×9	T15
EMR C25-5R25-250-2T	25	25	70	250	2		M4×9	T15
EMRW C25-6R25-150-2T	25	25	50	150	2		RPMT 1204 MO	M4×9
EMRW C32-6R32-150-2T	32	32	50	150	2	M4×9		T15
EMRW C32-6R32-200-2T	32	32	50	200	2	M4×9		T15
EMRW C32-6R32-250-2T	32	32	60	250	2	M4×9		T15
EMRW C32-6R32-300-2T	32	32	60	300	2	M4×9		T15

EMRW (FACE MILL)

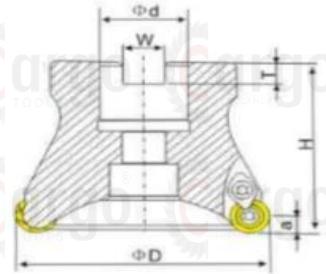

PRODUCT NAME	DIA	HOLE DIA	HIGHT	W	T	SUITABLE INSERT	SCREW	FLAG KEY
EMRW 6R50-22-4T	50	22	47	10.4	6.3	RPMT 1204	M4X10	T15
EMRW 6R63-22-4T	63	22	47	10.4	6.3			
EMRW 6R80-27-6T	80	27	50	12.4	7			
EMRW 6R100-32-6T	100	32	50	14.4	8			
EMRW 6R125-40-7T	125	40	60	16.4	9			
EMRW 6R160-40-8T	160	40	60	16.4	9			
EMRW 6R200-40-10T	200	40	60	25.7	14			

APMT INSERT CUTTER

BAP300R/400R (SIDE MILL CUTTER)



PRODUCT SIZE	DIAMENSIONS				NO. OF EDGES	SUITABLE INSERT	SCREW	SCREW DRIVER	
	BLADE DIA (D)	SHANK DIA (d)	L1	L					
BAP 300R C10-10-120-1T	10	10	30	120	1	A P M T	M2.5×6	T8	
BAP 300R C12-12-130-1T	12	12	30	120	1		M2.5×6	T8	
BAP 300R C14-14-130-2T	14	14	30	130	2		M2.5×6	T8	
BAP 300R C14-14-150-2T	14	14	30	150	2		M2.5×6	T8	
BAP 300R C16-16-120-2T	16	16	40	120	2		M2.5×6	T8	
BAP 300R C16-16-150-2T	16	16	50	150	2		M2.5×6	T8	
BAP 300R C16-16-200-2T	16	16	60	200	2		M2.5×6	T8	
BAP 300R C20-20-120-2T	20	20	35	120	2		M2.5×6	T8	
BAP 300R C20-20-150-2T	20	20	50	150	2		M2.5×6	T8	
BAP 300R C20-20-200-2T	20	20	60	200	2		M2.5×6	T8	
BAP 300R C20-20-250-2T	20	20	60	250	2	I I 3 5	M2.5×6	T8	
BAP 300R C25-25-150-3T	25	25	50	150	3		M2.5×6	T8	
BAP 300R C25-25-200-3T	25	25	60	200	3		M2.5×6	T8	
BAP 300R C25-25-250-3T	25	25	60	250	3		M2.5×6	T8	
BAP 400R C25-25-150-2T	25	25	50	150	2		A P M T I 6 0 4	M4×9	T15
BAP 400R C25-25-200-2T	25	25	60	200	2			M4×9	T15
BAP 400R C25-25-250-2T	25	25	70	250	2	M4×9		T15	
BAP 400R C32-32-150-3T	32	32	50	150	3	M4×9		T15	
BAP 400R C32-32-200-3T	32	32	60	200	3	M4×9		T15	
BAP 400R C32-32-250-3T	32	32	60	250	3	M4×9		T15	
BAP 400R C32-32-300-3T	32	32	60	300	3	M4×9		T15	
BAP 400R C32-32-350-3T	32	32	60	350	3	M4×9		T15	

BAP400R (FACE MILL)

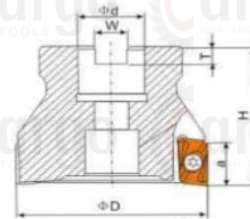

PRODUCT NAME	DIA	HOLE DIA	HIGHT	W	T	SUITABLE INSERT	SCREW	FLAG KEY
BAP400R 50-22-4T	50	22	47	10.4	6.3	APMT 1604	M4X10	T15
BAP400R 63-22-4T	63	22	47	10.4	6.3			
BAP400R 80-27-6T	80	27	50	12.4	7			
BAP400R 100-32-6T	100	32	50	14.4	8			
BAP400R 125-40-7T	125	40	60	16.4	9			
BAP400R 160-40-8T	160	40	60	16.4	9			
BAP400R 200-40-10T	200	40	60	25.7	14			

JDMW INSERT CUTTER



PRODUCT SIZE	DIAMENSIONS				NO. OF EDGES	SUITABLE INSERT	SCREW	SCREW DRIVER
	BLADE DIA	SHANK DIA	LI	L				
AJX08 C20-20-150-2T	20	20	40	150	2	JDMW 08	M3.5X8	T15
AJX08 C20-20-200-2T	20	20	40	200	2		M3.5X8	T15
AJX08 C20-21-150-2T	21	20	50	150	2		M3.5X8	T15
AJX08 C20-21-200-2T	21	20	50	200	2		M3.5X8	T15
AJX09 C25-25-150-2T	25	25	40	150	2	JDMW 0903	M3.5X8	T15
AJX09 C25-25-200-2T	25	25	50	200	2		M3.5X8	T15
AJX09 C25-26-150-2T	25	26	40	150	2		M3.5X8	T15
AJX09 C25-26-200-2T	26	26	50	200	2		M3.5X8	T15
AJX12 C32-32-150-3T	32	32	50	150	3	JDMW 1204	M4X9	T15
AJX12 C32-32-200-3T	32	32	60	200	3		M4X9	T15
AJX12 C32-32-250-3T	32	32	60	250	3		M4X9	T15

AJX12 (FACE MILL)



PRODUCT SIZE	DIAMENSIONS			NO. OF EDGES	SUITABLE INSERT	SCREW	SCREW DRIVER
	DIA	HOLE DIA	HIGHT				
AJX12 50-22-3T	50	22	47	3	JDMW1204	M4×10	T15
AJX12 63-22-4T	63	22	47	4			
AJX12 80-27-5T	80	27	60	5			
AJX14 50-22-3T	50	22	47	3	JDMW1405		
AJX14 63-22-4T	80	27	50	6			
AJX14 80-22-4T	100	32	50	6			
AJX14 100-32-5T	125	40	60	7			

SDMT INSERT CUTTER



PRODUCT SIZE	DIAMENSIONS			NO.OF EDGES	SUITABLE INSERT	SCREW	SCREW DRIVER
	DIA	HOLE DIA	HIGHT				
ASFR12 50-22-4T	50	22	47	4	SDMT I2	M4×10	Ti5
ASFR12 63-22-4T	63	22	47	4			
ASFR12 80-27-5T	80	27	60	5			
ASFR12 100-32-6T	50	22	47	6			
ASFR12 125-40-7T	80	27	50	7			
ASFR12 160-40-8T	100	32	50	8			

SNMU INSERT CUTTER



PRODUCT SIZE	DIAMENSIONS			NO.OF EDGES	SUITABLE INSERT	SCREW	SCREW DRIVER
	DIA	HOLE DIA	HIGHT				
MFB45-50-22-5T	50	22	47	5	S 1 N 2 M 0 U 6	M5X10	T20
MFB45-63-22-6T	63	22	47	6			
MFB45-80-27-7T	80	27	50	7			
MFB88-50-22-5T	50	22	47	5			
MFB88-63-22-6T	63	22	47	6			
MFB88-80-27-7T	80	27	50	7			
MFB88-100-32-8T	100	32	50	8			
MFB88-125-40-8T	125	40	63	8			

NBH2084 Micro Finishing Boring Kit

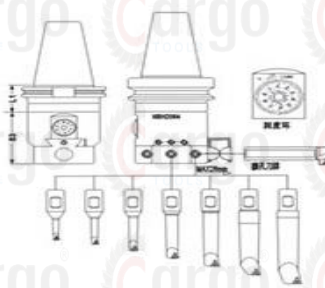

MODEL	BORING RANGE	TURNING PRECISION	MAX OFFSET	WEIGHT (KG)
NBH2084	8-280MM	0.01MM	28.0MM	3

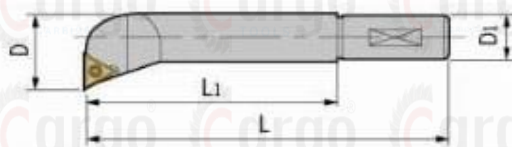

MODEL	SIZE(MM)				BORING RANGE	INSERT	SCREW	WRENCH
	D	D1	L1	L				
SBJ2008-32	8	20	32	80	8.0-11.0	TPGH 0601**	M2.0X5	T6
SBJ2010-40	10	20	40	97	10.0-13.0			
SBJ2012-53	12	20	53	98	12.0-17.0	TPGX 0902**	M2.5X6	T8
SBJ2016-68	16	20	68	110	16.0-21.0			
SBJ2020-83	20	20	83	123	20.0-25.0	TPGX 1103**	M3.0X8	T10
SBJ2025-96	25	20	96	137	25.0-135			
SBJ2030-115	30	20	115	152	30.0-140			
SBJ20-20-97	30	20	100	97	120-180			

FINISH BORING HEAD

BORING

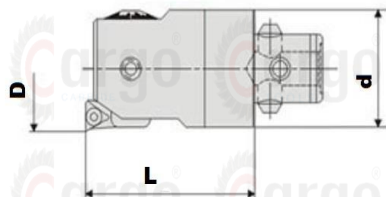

BACK BORING

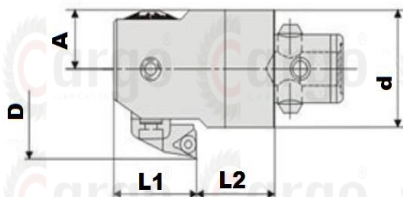

SPECIFICATION	BORING			BACK BORING			INSERT HOLDER	INSERT SIZE	SCREW OR WENCH	
	BORING RANGE (D)	d	L	BORING RANGE (D)	L1	L2				A
CKB1-EWN2036-32.5	20-26	19	32.5	30-31	20	10	10	ENH1-1	TPGX 0802**	M2.2X5 T7
	25-31			30-36				ENH1-2		
	30-36			ENH1-3						
CKB2-EWN2547-35.5	25-33	24	35.5	36-40	22	10	12.5	ENH2-1		
	32-40			39-47				ENH2-2		
	39-47			ENH2-3						
CKB3-EWN3260-40	32-42	31	40	46-51	25	9	16	ENH3-1		
	41-51			50-60				ENH3-2		
	50-60			ENH3-3						
CKB4-EWN4174-47	41-54	39	47	58-66	30	13	20	ENH4-1		
	53-66			61-74				ENH4-2		
	61-74			ENH4-3						
CKB5-EWN5395-57	53-70	49	57	62-70	34	19	25.5	ENH5-1		
	68-85			78-95				ENH5-2		
	78-95			ENH5-3						
CKB6-EWN68150-71	68-100	63	71	80-100	45	23	32.5	ENH6-1		
	93-125			125-150				ENH6-2		
	125-150			ENH6-3						
CKB6-EWN100203-71	100-153	63	71	112-153	45	23	45.5	ENH6-1		
	125-178			150-203				ENH6-2		
	150-203			ENH6-3						

ROUGH BORING HEAD

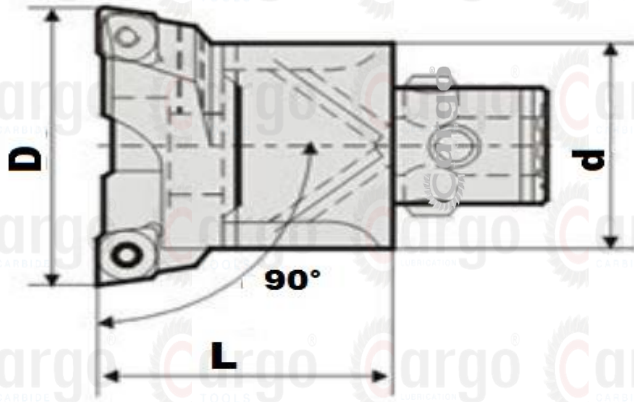

SPECIFICATION	BORING			INSERT SIZE	SCREW	WRENCH	INSERT HOLDER
	BORING RANGE (D)	d	L				
CKB1-TWN2026-35	20-26	19	35	CCMT 0602**	M2.5X7	T8	TW20-26M
CKB2-TWN2533-38	25-33	24	38				TW25-33M
CKB3-TWN3242-43	32-42	31	43	CCMT 09T3**	M4X10	T15	TW32-42M
CKB4-TWN4154-50	41-54	39	50				TW41-54M
CKB5-TWN5372-60	53-70	49	60	CCMT 1204**	M5X13	T20	TW53-72M
CKB6-TWN6890-75	68-90	63	75				TW68-90M
CKB6-TWN89120-75	89-120	63	75				TW89-120M
CKB6-TWN115150-75	115-150	63	75				TW115-150M



M10 CLAMPING KIT

T-SLOT SIZE	T-NUT (6 nos.)	STUD (4 nos. Each size)	FLANGED NUT (6 nos.)	EXTENSION NUT (4 nos.)	STRAP CLAMPS (2 nos. Each size)	STEP BLOCKS (4 nos. Each size)	NO. OF PIECES	WEIGHT (kg.)
12MM 14MM	TN 12-10 TN 14-10	CS10-75 CS10-100 CS10-125 CS10-150 CS10-175 CS10-200	FN-10	EN-10	SC10-60 SC10-80 SC10-120	SB-1L SB-2L SB-3L	58	9.5

M12 CLAMPING KIT

T-SLOT SIZE	T-NUT (6 nos.)	STUD (4 nos. Each size)	FLANGED NUT (6 nos.)	EXTENSION NUT (4 nos.)	STRAP CLAMPS (2 nos. Each size)	STEP BLOCKS (4 nos. Each size)	NO. OF PIECES	WEIGHT (kg.)
14MM 16MM 18MM	TN 14-12 TN 16-12 TN 18-12	CS12-75 CS12-100 CS12-125 CS12-150 CS12-175 CS12-200	FN-12	EN-12	SC12-65 SC12-100 SC12-125	SB-1 SB-2 SB-3	58	13

M16 CLAMPING KIT

T-SLOT SIZE	T-NUT (6 nos.)	STUD (4 nos. Each size)	FLANGED NUT (6 nos.)	EXTENSION NUT (4 nos.)	STRAP CLAMPS (2 nos. Each size)	STEP BLOCKS (4 nos. Each size)	NO. OF PIECES	WEIGHT (kg.)
18MM 20MM 22MM	TN 18-16 TN 20-16 TN 22-16	CS16-75 CS16-100 CS16-125 CS16-150 CS16-175 CS16-200	FN-16	EN-16	SC16-65 SC16-100 SC16-125	SB-1 SB-2 SB-3	58	19

CARBIDE FLAT ENDMILL



FLAT ENDMILL	D1	FLUTE LENGTH (L1)	LENNGTH (L)	SHANK DIA (D2)	NUMBR OF FLUTES
D1 X 5 X 50 -4F	1	5	50	4	4F
D1.5 X 5 X 50 -4F	1.5	5	50	4	4F
D2 X 6 X 50 -4F	2	6	50	4	4F
D2.5 X 8 X 50 -4F	2.5	8	50	4	4F
D3 X 12 X 50 -4F	3	8	50	3	4F
D3 X 20 X 75 -4F	3	20	75	3	4F
D3 X 25 X 100 -4F	3	25	100	3	4F
D4 X 15 X 50 -4F	4	15	50	4	4F
D4 X 20 X 75 -4F	4	20	75	4	4F
D4 X 25 X 100 -4F	4	25	100	4	4F
D5 X 15 X 50 -4F	5	15	50	5	4F
D5 X 20 X 75 -4F	5	20	75	5	4F
D5 X 30 X 100 -4F	5	30	100	5	4F
D6 X 20 X 50 -4F	5	20	50	6	4F
D6 X 20 X 75 -4F	6	20	75	6	4F
D6 X 30 X 100 -4F	6	30	100	6	4F
D6 X 35 X 150 -4F	6	35	150	6	4F
D8 X 20 X 60 -4F	8	20	60	8	4F
D8 X 30 X 75 -4F	8	30	75	8	4F
D8 X 35 X 100 -4F	8	35	100	8	4F
D8 X 50 X 150 -4F	8	50	150	8	4F
D10 X 30 X 75 -4F	10	30	75	10	4F
D10 X 40 X 100 -4F	10	40	100	10	4F
D10 X 50 X 150 -4F	10	50	150	10	4F
D12 X 30 X 75 -4F	12	30	75	12	4F
D12 X 45 X 100 -4F	12	45	100	12	4F
D12 X 50 X 150 -4F	12	50	150	12	4F
D12 X 60 X 200 -4F	12	60	200	12	4F
D16 X 50 X 100 -4F	16	50	100	16	4F
D16 X 55 X 150 -4F	16	55	150	16	4F
D20 X 50 X 100 -4F	20	50	100	20	4F
D20 X 55 X 150 -4F	20	55	150	20	4F

CARBIDE BALLNOSE ENDMILL

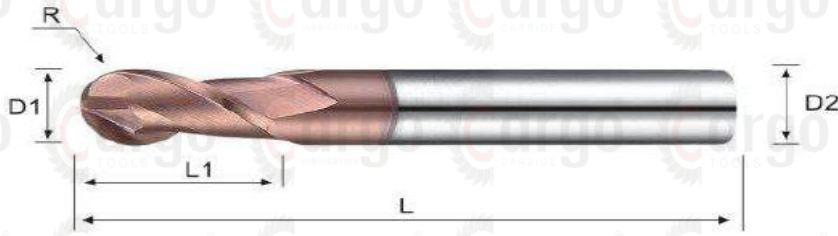

FLAT ENDMILL	D1	FLUTE LENGTH (L1)	LENNGTH (L)	SHANK DIA (D2)	NUMBR OF FLUTES
D1 X 5 X 50 -4F	1	5	50	4	4F
D1.5 X 5 X 50 -4F	1.5	5	50	4	4F
D2 X 6 X 50 -4F	2	6	50	4	4F
D2.5 X 8 X 50 -4F	2.5	8	50	4	4F
D3 X 12 X 50 -4F	3	8	50	3	4F
D3 X 20 X 75 -4F	3	20	75	3	4F
D3 X 25 X 100 -4F	3	25	100	3	4F
D4 X 15 X 50 -4F	4	15	50	4	4F
D4 X 20 X 75 -4F	4	20	75	4	4F
D4 X 25 X 100 -4F	4	25	100	4	4F
D5 X 15 X 50 -4F	5	15	50	5	4F
D5 X 20 X 75 -4F	5	20	75	5	4F
D5 X 30 X 100 -4F	5	30	100	5	4F
D6 X 20 X 50 -4F	5	20	50	6	4F
D6 X 20 X 75 -4F	6	20	75	6	4F
D6 X 30 X 100 -4F	6	30	100	6	4F
D6 X 35 X 150 -4F	6	35	150	6	4F
D8 X 20 X 60 -4F	8	20	60	8	4F
D8 X 30 X 75 -4F	8	30	75	8	4F
D8 X 35 X 100 -4F	8	35	100	8	4F
D8 X 50 X 150 -4F	8	50	150	8	4F
D10 X 30 X 75 -4F	10	30	75	10	4F
D10 X 40 X 100 -4F	10	40	100	10	4F
D10 X 50 X 150 -4F	10	50	150	10	4F
D12 X 30 X 75 -4F	12	30	75	12	4F
D12 X 45 X 100 -4F	12	45	100	12	4F
D12 X 50 X 150 -4F	12	50	150	12	4F
D12 X 60 X 200 -4F	12	60	200	12	4F
D16 X 50 X 100 -4F	16	50	100	16	4F
D16 X 55 X 150 -4F	16	55	150	16	4F
D20 X 50 X 100 -4F	20	50	100	20	4F
D20 X 55 X 150 -4F	20	55	150	20	4F

CARBIDE CORNER -RADIUS ENDMILL

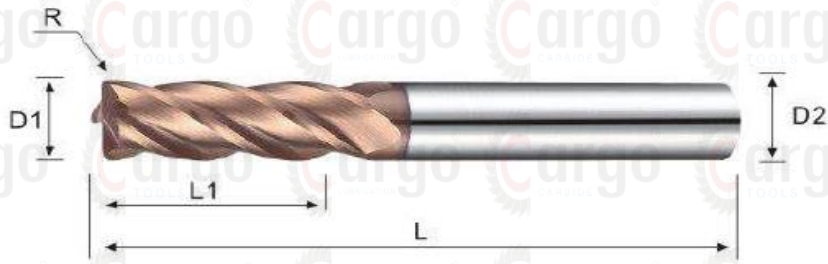

FLAT ENDMILL	D1	FLUTE LENGTH (L1)	LENNGTH (L)	SHANK DIA (D2)	NUMBR OF FLUTES
--------------	----	-------------------	-------------	----------------	-----------------

CORNER RADIUS 1.0

D3 X 12 X 50 -4F	3	8	50	3	4F
D4 X 15 X 50 -4F	4	15	50	4	4F
D4 X 20 X 75 -4F	4	20	75	4	4F
D5 X 15 X 50 -4F	5	15	50	5	4F
D5 X 20 X 75 -4F	5	20	75	5	4F
D5 X 30 X 100 -4F	5	30	100	5	4F
D6 X 20 X 50 -4F	5	20	50	6	4F
D6 X 20 X 75 -4F	6	20	75	6	4F
D6 X 30 X 100 -4F	6	30	100	6	4F
D8 X 35 X 100 -4F	8	35	100	8	4F
D10 X 30 X 75 -4F	10	30	75	10	4F
D10 X 40 X 100 -4F	10	40	100	10	4F
D12 X 30 X 75 -4F	12	30	75	12	4F
D12 X 45 X 100 -4F	12	45	100	12	4F

CORNER RADIUS 0.5

D3 X 12 X 50 -4F	3	8	50	3	4F
D4 X 15 X 50 -4F	4	15	50	4	4F
D4 X 20 X 75 -4F	4	20	75	4	4F
D5 X 15 X 50 -4F	5	15	50	5	4F
D5 X 20 X 75 -4F	5	20	75	5	4F
D5 X 30 X 100 -4F	5	30	100	5	4F
D6 X 20 X 50 -4F	5	20	50	6	4F
D6 X 20 X 75 -4F	6	20	75	6	4F
D6 X 30 X 100 -4F	6	30	100	6	4F
D8 X 35 X 100 -4F	8	35	100	8	4F
D10 X 30 X 75 -4F	10	30	75	10	4F
D10 X 40 X 100 -4F	10	40	100	10	4F
D12 X 30 X 75 -4F	12	30	75	12	4F
D12 X 45 X 100 -4F	12	45	100	12	4F



Cargo[®]
CARBIDE



Cargo[®]
TOOLS



Cargo[®]
LUBRICATION



**QUALITY
FIRST**

Cargo's prime focus is to provide quality products across the vast product basket.



**PREMIUM AND
ECONOMIC PRICING**

Cargo makes product lines that ranges from premium quality to economic pricing.



**DECADES OF
EXPERIENCE**

The promoters have 35 years of experience in providing quality abrasive products.



**ON TIME
DELIVERY**

Cargo believes in giving the best service to its customers to fulfill all their requirements.